

*** TM 10-227**

TECHNICAL MANUAL
FITTING OF ARMY UNIFORMS
AND FOOTWEAR

DISTRIBUTION STATEMENT A: Approved for public release; distribution is unlimited.

* This manual supersedes TM 10-227, dated 29 July 1994

HEADQUARTERS, DEPARTMENT OF THE ARMY
30 DECEMBER 2000

THIS PAGE INTENTIONALLY LEFT BLANK

INSERT LATEST UPDATED PAGES/WORK PACKAGES, DESTROY SUPERSEDED DATA.

LIST OF EFFECTIVE PAGES/WORK PACKAGES

NOTE: The portion of the text affected by the updates is indicated by a vertical line in the outer margins of the page. Changes to Illustrations are indicated by miniature pointing hands. Changes to wiring diagrams are indicated by shaded areas

Dates of issue for original and updated pages/work packages are:

Original..... 0 ...30 Dec 00
 Revision 1 ...

TOTAL NUMBER OF PAGES FOR FRONT AND REAR MATTER IS 84 AND TOTAL NUMBER OF WORK PACKAGES IS 0 CONSISTING OF THE FOLLOWING:

| Page/WP No. | *Change No. | Page/WP No. | *Change No. | Page/WP No. | *Change No. |
|-------------|-------------|-------------|-------------|-------------|-------------|
| i - iii | 0 | | | | |
| 1-1 | 0 | | | | |
| 1-2 | 0 | | | | |
| 2-1 -- 2-4 | 0 | | | | |
| 3-1 - 3-14 | 0 | | | | |
| 4-1 - 4-21 | 0 | | | | |
| 5-1 - 5-8 | 0 | | | | |
| 6-1 - 6-11 | 0 | | | | |
| A-1 | 0 | | | | |
| B-1 - B-4 | 0 | | | | |

THIS PAGE INTENTIONALLY LEFT BLANK

TECHNICAL MANUAL
NO. 10-227

HEADQUARTERS
DEPARTMENT OF THE ARMY
WASHINGTON, D.C., 30 December 2000

FITTING OF ARMY UNIFORMS AND FOOTWEAR

REPORTING ERRORS AND RECOMMENDING IMPROVEMENTS

You can help improve this manual. If you find any mistakes, or if you know of a way to improve these procedures, please let us know. Mail your letter or DA Form 2028 (Recommended Changes to Publications and Blank Forms), or DA Form 2028-2 located in the back of this manual directly to: Commander, US Army Soldier and Biological Chemical Command, ATTN: AMSSB-RIM-E(N), Kansas Street, Natick, MA, 01760-5052. You may also submit your recommended changes by E-mail directly to <amsscsr@natick-amed02.army.mil>. A reply will be furnished directly to you. Instructions for sending an electronic 2028 may be found at the back of this manual immediately preceding the hard copy 2028.

DISTRIBUTION STATEMENT A: Approved for public release; distribution is unlimited

TABLE OF CONTENTS

| | PAGE |
|--|-------------|
| CHAPTER 1 INTRODUCTION | 1-1 |
| CHAPTER 2 GENERAL FITTING PROCEDURES | 2-1 |
| CHAPTER 3 FITTING OF MEN'S UNIFORMS | 3-1 |
| CHAPTER 4 FITTING OF WOMEN'S UNIFORMS | 4-1 |
| CHAPTER 5 FITTING OF BATTLEDRESS UNIFORM AND COAT, CW (FIELD JACKET) | 5-1 |
| CHAPTER 6 FITTING OF FOOTWEAR ITEMS | 6-1 |
| APPENDIX A REFERENCES | A-1 |
| APPENDIX B NSN, LIN, SPECIFICATION NUMBER, AND NOMENCLATURE LISTING | B-1 |

* This manual supersedes TM 10-227, dated 29 July 1994*

LIST OF TABLES

| Table Number | Title | Page |
|-----------------|---|------|
| 2-1 | Authorized Alterations to Men's Uniform Items | 2-4 |
| 2-2 | Authorized Alterations to Women's Uniform Items | 2-4 |
| 3-1 | Size for Men's Short Sleeve Shirts | 3-3 |
| 3-2 | Size for Men's Long Sleeve Shirts | 3-3 |
| 3-3 | Size Prediction for Men's Army Green Service Trousers | 3-4 |
| 3-4 | Size Prediction for Men's Army Green Service Coats | 3-5 |
| 3-5 | Size Prediction for Men's Caps | 3-7 |
| 3-6 | Size Prediction for the All Weather Coat for Male Personnel | 3-8 |
| 4-1 | Size Prediction Chart for Women's Items | 4-16 |
| 5-1 | Trousers, BDU, Size Prediction Table | 5-3 |
| 5-2 | Coat, BDU, Size Prediction Table | 5-4 |
| 5-3 | Cap, BDU, Size Prediction Table | 5-4 |
| 5-4 | Coat, Cold Weather (Field Jacket), Size Prediction Table | 5-5 |
| 6-1 | Size Correlation Chart for Socks | 6-3 |

LIST OF ILLUSTRATIONS

| Figure Number | Title | Page |
|------------------|---|------|
| 2-1 | Key Points of Fitting Measurements | 2-2 |
| 2-2 | Basic Body Measurements | 2-3 |
| 3-1 | Fit of Men's Uniform Coat and Trousers | 3-9 |
| 3-2 | Fit of Men's Shirt and Trousers | 3-10 |
| 3-3 | Proper Fit of Cap | 3-12 |
| 3-4 | Proper Fit of Men's All Weather Coat | 3-13 |
| 4-1 | Body Size Prediction Chart Measurement Diagrams for Women | 4-4 |
| 4-2 | Fit of Women's Uniform Shirt and Skirt | 4-10 |
| 4-3 | Fit of Women's Uniform Shirt and Slacks | 4-11 |
| 4-4 | Fit of Women's Uniform Coat and Slacks/Coat and Skirt | 4-13 |
| 4-5 | Fit of Women's All Weather Coat | 4-15 |
| 5-1 | Fit of Battledress Uniform (Hot Weather or Temperate) | 5-7 |
| 5-2 | Fit of Coat, Cold Weather (Field Jacket) | 5-8 |
| 6-1 | Proper Fitting of Footwear | 6-2 |
| 6-2 | Operating Procedures for Foot Measuring Device | 6-4 |
| 6-3 | Measuring Arch Fit | 6-6 |
| 6-4 | Proper and Improper Arch Fit | 6-6 |
| 6-5 | Locating Ball Joint Arch Fit | 6-7 |
| 6-6 | Proper and Improper Ball Joint | 6-8 |
| 6-7 | Proper and Improper Shoe/Boot Width | 6-9 |
| 6-8 | Proper and Improper Foot Clearance in Shoe | 6-10 |
| 6-9 | Shoe Fitting Program | 6-11 |

THIS PAGE INTENTIONALLY LEFT BLANK

CHAPTER 1

INTRODUCTION

1-1. PURPOSE AND SCOPE To provide a guide for Commanders and personnel engaged in the fitting of uniforms and foot wear for both male and female soldiers.

1-2 REPORTING OF ERRORS, OMISSIONS AND RECOMMENDATIONS. The reporting of errors, omissions and recommendations for improving this manual is encouraged. Reports should be submitted on DA Form 2028, Recommended Changes to Publications and Blank Forms. Forward completed forms to Commander, US Army Soldier Systems Command, Natick RD&E Center, ATTN: AMSSB-RIM-E(N), Natick, MA 01760-5052. Reasons should be provided on each comment to ensure complete understanding of the recommendation for proper evaluation.

1-3 RESPONSIBILITIES. Commanders, at all levels, are responsible for ensuring that all personnel in their command have properly fitted uniforms and footwear.

1-4 DEFINITIONS.

a. Body Measurement. An individual's physical dimensions measured over the underclothing usually worn.

b. Drop. The difference between an individuals chest and waist measurements. The normal drop ranges from four to seven inches.

c. Model. Model refers to the length of the garment. Ordinarily, five separate lengths (models) are established: extra short (XS), short (S), regular (R), long (L) and extra long (XL).

d. Sizing System. Clothing items are supplied in sizes according to importance of fit.

(1) Adjective Size. When an exact fit is not critical, the item is supplied in five or six sizes, with each size fitting a certain range of body measurements. For example, a size large undershirt will fit individuals with chest measurements ranging from 42 to 44 inches.

(2) Numeric Size. When an exact fit is critical, items are supplied in many sizes: one size for each inch of body measurement. Uniform coats are available in 70 separate sizes. An example of numerical sizing is 40 extra short, 40 short, 40 regular, 40 long, and 40 extra long.

e. Special Measurement Sizes. Special measurement clothing and footwear is provided to personnel who cannot be properly fitted through alterations to standard tariff sizes. Special measurement sizes may include tariff sizes which must be altered radically to compensate for an individual's physical measurement.

TM 10-227

f. Subgarments. Items of clothing that are worn under the garment being fitted, or items as belts/buckles.

g. Tariff Size. Tariff refers to the worldwide frequency of issue of each size within the total size range of a particular clothing or footwear item. It is used to justify procurement for stockage within the supply system.

CHAPTER 2

GENERAL FITTING PROCEDURES

2-1. APPROVED CONCEPT OF FIT The approved concept of fit for uniforms and individual garments pertains to the Army concept of proper appearance when an individual is fitted according to correct size and measurement

2-2. FITTING PROCEDURES

a Physical Measurements. Measure using tape, NSN 8315-00-792-9000, and record the basic body measurements of each individual (Figs 2-1 and 2-2) to determine the initial size for selection of the try-on garment. Each measurement must be taken over the appropriate subgarment to ensure proper fit.

b Initial Selection for Try-On. Using results of the physical measurements, make selection of the initial try-on garment by referring to the size prediction tables provided for each type of garment. To ensure the best possible fit from tariff sizes, each individual wearing the proper subgarments, may require a minimum of two sizes for try-on..

c Marking for Alterations. When the fitter decides that an individual cannot be properly fitted from tariff sizes, the closest fitting item will be put on and marked for alterations (see Tables 2-1 and 2-2 for authorized alterations). If the number and types of alterations are excessive or the proper fit cannot be obtained, request for special measurement clothing will be prepared and submitted in accordance with AR 700-84

d Final Check. When alterations have been completed, the garment should be put on and checked for proper fit. If necessary, make additional alterations. The jacket and trousers should fit smoothly with no vertical, horizontal, or diagonal wrinkles or creases. Horizontal creases usually indicate the garment is too tight; vertical creases indicate the garment is too loose; and in jackets, diagonal creases in the shoulder area generally indicate that one shoulder is lower than the other..

2-3. REQUEST FOR SPECIAL MEASUREMENT CLOTHING AND FOOTWEAR.

a Special Measurement Clothing. Special measurement clothing; is authorized only for persons who cannot be properly fitted with standard tariff sizes or by authorized alterations. Unless directed otherwise, service members take all special measurement clothing with them on permanent change of station. For supply procedures of special measurement clothing see AR 700-84.

b Special Measurement Footwear. Special measurement footwear is authorized only for soldiers who cannot be properly fitted with standard tariff sizes stocked in the depot supply system. Orthopedic footwear and orthopedic adjustment to standard footwear are not authorized under this provision. Special measurement footwear is included under the clothing and allowance system. Detailed supply procedures are in AR 32-4 (AR 700-84).

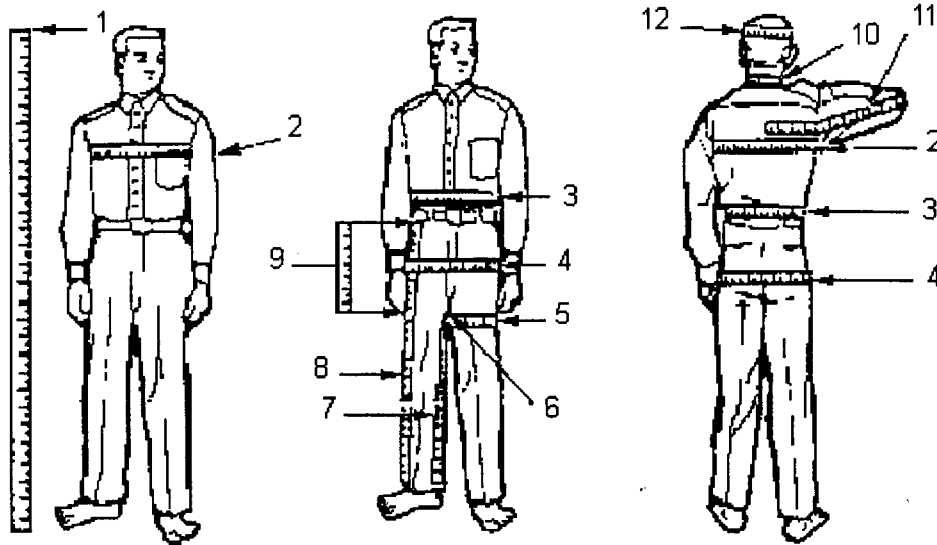

1. HEIGHT

From floor to natural height with subject standing in an erect manner. This measurement must be exact, as it regulates the length of the coat and the depth of the waist.

2. CHEST

Place tape well up under arms and over the shoulder blades on a horizontal line, taking the floor as a level. This measurement is taken snug. Take measurement from center of back instead of the front, with the subject standing in a natural position and not with the chest fully expanded.

3. WAIST

Measure around waist on the shirt just above the trousers at a point directly over the hipbones; snug, but not tight.

4. SEAT

Measure around the largest part of the hips or seat.

5. WIDTH OF LEG

Measure around the thigh, just below the crotch level.

6. CROTCH

The part of the human body where the legs fork from the pelvis. This is not a measurement, but is a point from which measurements are taken.

7. INSEAM

Place the tape firm and well up against the crotch at (6), and measure down to the floor along the leg of the inside seam and then subtract 2-1/2 inches.

8. OUTSEAM

Place the tape on the subject just above the hipbone, on the lower edge of the waistband seam, and measure to the bottom of the trousers. This measurement is taken along the length of the outside seam.

9. RISE

This measurement is the difference between the inseam and outseam measurements.

10. NECK

Measure the circumference of the neck at the collar line and add 1/2 inch for ease.

11. SLEEVE

Raise arm of the subject and bend the arm at right angle, bringing forward the forearm parallel to the floor, with palms down; measure from center of back to sleeve seam, continuing around the elbow to the wristbone. This measurement gives the full sleeve length.

12. HEAD

Measure the circumference of the head with the tape across the forehead and over temples.

Figure 2-1. Key Points of Fitting Measurements.

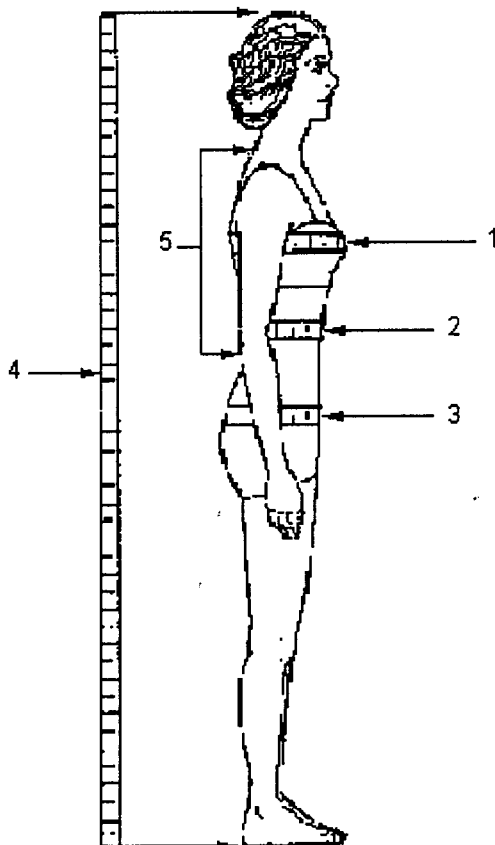

1. BUST GIRTH - Around fullest part of bust.
2. WAIST GIRTH - Around smallest part of waist.
3. HIP GIRTH - Around fullest part of hip.
4. HEIGHT -Stature without shoes.
5. BACK WAIST LENGTH -From Back neck to waist level.

Figure 2-2. Basic Body Measurements.

c Orthopedic Footwear. Corrective, compensating, or remedial boots or shoes manufactured on a special orthopedic last are considered to be orthopedic footwear and will be medically prescribed in all cases where disabled or deformed feet cannot be fitted satisfactorily with footwear available in regular supply channels modified by orthopedic adjustments. Orthopedic footwear as defined are medical appliances and will be requisitioned from the Defense Orthopedic Footwear Clinic (DOFC), Boston, MA (see AR 40-3)..

Table 2-1 Authorized Alterations to Men's Uniform Items.

| <u>Alteration</u> | Army Black | | All Weather | |
|--------------------|-------------|------------------|---------------|--------------|
| | <u>Coat</u> | <u>Trousers*</u> | <u>Coat**</u> | <u>Shirt</u> |
| Armhole | - | - | X | - |
| Shoulders | - | - | X | - |
| Collar | - | - | X | - |
| Sleeves | X | - | X | X |
| Side or Back Seams | - | - | X | X |
| Bottoms | - | X | - | - |
| Crotch | - | X | - | - |
| Seat | - | X | - | - |
| Waist | - | X | - | - |
| Hemline | X | - | - | - |
| Button Alignment | - | - | X | X |
| Braid Attachment | - | X | X | - |

*The only alteration for the BDU Trousers is shortening the length.

**Alteration of BDU Coat is not authorized.

Table 2-2 Authorized Alterations to Women's Uniform Items.

| <u>Alteration</u> | Army Black | | All Weather | | |
|-----------------------------|-------------|--------------|--------------|-------------------------------|--------------|
| | <u>Coat</u> | <u>Coat*</u> | <u>Skirt</u> | <u>Slacks/ Trousers**</u> | <u>Shirt</u> |
| Shoulders | - | X | - | - | - |
| Collar | - | X | - | - | - |
| Sleeves | X | X | - | - | X |
| Side,Back or Princess Seams | - | X | - | - | X |
| Backwaist Length | - | X | - | - | - |
| Bottoms | - | - | - | X | - |
| Crotch | - | - | - | X | - |
| Hip | - | - | X | X | - |
| Waist | - | - | X | X | - |
| Hemline | X | X | X | - | - |
| Button Alignment | X | X | - | - | - |
| Braid Attachment | - | X | - | X | - |
| Bust | - | X | - | - | - |
| Lining | - | - | X | - | - |

*Alteration of BDU Coat is not authorized.

**The only alteration for the BDU Trousers is shortening the length.

CHAPTER 3

FITTING OF MEN'S UNIFORMS

3-1. MEN'S UNIFORM ITEMS. The Men's uniform is composed of an Army Green Shade 489 Coat and Trousers, an Army green Shade 415 Long or Short Sleeve Shirt, and the Cap, Garrison. A Coat, All-Weather, Black Shade 385, may be worn over the uniform

a. Design:

(1) *Coat.* The Coat is a four-button, single breasted coat, plain edge, peaked lapel and a notched collar. It is designed to fit slightly at the waist to conform with the individual's figure.

(2) *Trouser.* The trousers have a plain zipper front with an unfinished bottom. They are designed to fit smoothly, but not tightly, around hips, seat, and waist, with a slight fullness for comfort. The rise is automatically built into the trousers and varies with different lengths.

(3) *Shirt.* The shirt is a dress type shirt with seven buttons and two pleated pockets with button flaps. The shirt is available in both long and short sleeves. The long sleeve shirt has two—button interlined cuffs and is designed to be worn strictly with a tie.

(4) *Cap, Garrison.* The cap is dress type, garrison style cap, having a crown and outside turned curtain, with the ends crossing at the front. The top edge is furnished with a cord-edged braid.

(5) *All Weather Coat.*

(a) All Weather Coat. The all weather Army black coat is a six-button, double-breasted model with a belt. The Coat has a convertible collar (button at neck), gun flap, shoulder loops, adjustable sleeve straps and welt pockets with two inside hanging pockets. The back has a yoke and center vent.

(b) Liner. The detachable liner has button loops at the bottom of each sleeve and zipper around the edge for attaching the liner to the coat. The coat is one-quarter lined.

b. Material:

(1) *Coat, Trousers, and Garrison Cap.* 11.5 ounce, Army Green 489.

(2) *Shirt.* Precured durable press, 65/35 polyester/cotton broadcloth, stock-dyed yarn in end-to-end configurations, 3.8-4.3 ounce, Army Green 415.

(3) *All Weather Coat.* 65/35 Polyester/cotton poplin. the color is Army Black 385.

c. Sizing System:

(1) *Coats.* Army coat sizes are related to the individual chest, height, and waist measurements. The coats are sized numerically by chest measurement and are available in extra short, short, regular, long, and extra long models.

(2) *Trousers.* Trousers are sized numerically according to waist measurement and are available in one-inch increments. Inseam lengths are available in five models; extra short, short, regular, long, and extra long. All trousers are labeled with waist size first, immediately followed by the inseam length.

(3) *Shirts.* Short sleeve shirts are available in 1/2-inch neck size increments from 14 through 18 inches. The long sleeve shirt is available in 1-inch sleeve length increments from 29 through 38 inches, with neck sizes in 1/2-inch increments from 14 through 18 inches

TM 10-227

(4) *Cap, Garrison.* The garrison cap is provided with 1/8-inch size increments from size 6 3/8 through 7 7/8.

(5) *All Weather Coat.* the all weather coat is available in two-inch size increments from size 30 through 48 and lengths extra short (XS), short (S), regular (R), long (L), and extra long (XL).

d. General Fitting Procedures.

(1) *Shirts.*

(a) Subgarment. The subgarment worn for try-on of the Army Green 415 Shirt is the cotton undershirt.

(b) Measurements.

1Neck Place the tape evenly, but not snugly around the middle of the neck, allowing 1/2-inch ease.

2Arm To obtain the full sleeve length, direct the individual being fitted to raise his arm parallel to the floor, bending it at the elbow to form a right angle with the palm of his hand facing the floor. The arm is then measured from the center of the back (parallel with the elbow) along the arm, around to the lower part of the wrist bone.

(c) Try-On Use the neck and sleeve measurements to determine the correct size for try-on, refer to Tables 3-1 and 3-2 for sizes of men's Short and Long Sleeve Shirts available.

(d) Alterations.

1Side Seams. Size seams may be taken in. Ease at waist will not be less than 1-1/4 inches at each side seam.

2Button Alignment. Neck button may be moved but not more than 1/4-inch.

3Sleeves. Shortening of the shirt sleeves is acceptable for the long sleeve shirt only. Utilize both buttons to obtain the concept of fit prior to altering sleeve length.

Table 3-1 Size Table For Men's Short Sleeve Shirts.

| Size | Neck Size (inches) |
|--------|-----------------------|
| 13-1/2 | 14 |
| 14 | 14-1/2 |
| 14-1/2 | 15 |
| 15 | 15-1/2 |
| 15-1/2 | 16 |
| 16 | 16-1/2 |
| 16-1/2 | 17 |
| 17 | 17-1/2 |
| 17-1/2 | 18 |

Table 3-2 Size Table For Men's Long Sleeve Shirts.

| Size | Neck Size (Inches) | Sleeve Length* (Inches) |
|--------|-----------------------|-------------------------------|
| 13-1/2 | 14 | 30-32 33 (N) |
| 14 | 14-1/2 | 29-34 35 (N) |
| 14-1/2 | 15 | 30-35 |
| 15 | 15-1/2 | 30-37 |
| 15-1/2 | 16 | 30-38 30 (N) |
| 16 | 16-1/2 | 31-38 32 (N) |
| 16-1/2 | 17 | 31-38 |
| 17 | 17-1/2 | 33-37 32 (N) & 34 (N) |
| 17-1/2 | 18 | 33 & 35 |

*One-inch sleeve lengths available as needed.

(N) = new item size only.

(2) Trousers..

(a) Subgarments. Subgarments required for fitting of trousers are cotton underwear, shirt, belt and brass buckle, socks and low quarter shoes.

(b) Measurements. The waist, seat, and hem line measurements are needed for the selection of the proper size and model try-on garment.

(c) Try-On Using the individuals waist, seat, and height measurements, refer to Table 3-3 for size prediction of initial try-on garment. Trousers are to be fitted to the seat. Make sure the bottom of the waist band is on top of the hip bone, plus or minus 1/2-inch, before measuring and making trousers.

(d) Alterations.

1Waist. Alteration of the waist consists of opening the backseam where outlet material has been provided and making necessary adjustments. To avoid improper hanging or dislocated pockets, the waist adjustment must not be more than 1-1/2 inches.

2Bottoms Measure and mark both trouser legs individually. Hem trousers to be measured length, turning up the bottoms as marked. If the proper length model has been selected, no more than a two-inch turn-up should be required. Stitching must not be visible on the outside of the trouser.

Table 3-3 Size Prediction Table For Men's Trousers.

| Waist (Inches) | Seat (Inches) | Height | | | | |
|-------------------|------------------|-----------|-----------|------------|------------|-----------|
| | | 5'0"-5'4" | 5'5"-5'7" | 5'8"-5'10" | 5'11"-6'1" | 6' 2"-Up |
| 26 | 34 | *26XS (P) | 26S (P) | 26R | *26L (P) | ... |
| 27 | 35 | ... | 27R | 27R | 27L (P) | ... |
| 28 | 36 | *28XS (P) | 28S | 28R | 28L | *28XL (P) |
| 29 | 37 | ... | 29S | 29R | 29L | *29XL |
| 30 | 38 | *30XS | 30S | 30R | 30L | 30XL |
| 31 | 39 | ... | 31S | 31R | 31L | 31XL (P) |
| 32 | 40 | *32XS (P) | 32S | 32R | 32L | 32XL |
| 33 | 41 | ... | 33S | 33R | 33L | 33XL |
| 34 | 42 | *34XS (P) | 34S | 34R | 34L | 34XL |
| 35 | 43 | ... | 35S | 35R | 35L | ... |
| 36 | 44 | ... | 36S | 36R | 36L | 36XL |
| 37 | 45 | ... | 37S | 37R | 37L | ... |
| 38 | 46 | ... | 38S | 38R | 38L | 38XL |
| 39 | 47 | ... | 39S | 39R | 39L | ... |
| 40 | 48 | ... | 40S (P) | 40R | 40L | *40XL |
| 41-42 | 49-50 | ... | ... | 42R (P) | 42L | ... |
| 43-44 | 51-52 | ... | ... | 44R | 44L | ... |

*Supplemental sizes which will be stocked at reception stations and key depots only.

(P) = Phase-out item size only.

3Crotch. Let out inseam at the back of the trousers and fill in hollow at the curve as much as possible. If the rise should be longer, take off the fly and sink the crotch the required length. Piece the top of the fly. Adjust the trouser length.

4Seat. Let out the outlet material inside the trouser at the seat. Note that if the seat needs to be altered, the crotch of the trousers must also be altered.

(3) Coat..

(a) SubGarments. Subgarments required for the fitting of the coat are cotton underwear, dress shirt, polyester/wool trousers, socks, low quarter shoes, belt and buckle.

(b) Measurements. The chest and height measurements are needed for selection of the proper size and model try-on garment.

(c) Try-On Using the individual's height and chest measurements, refer to Table 3-4, for size prediction of initial try-on garment. If the individual's measurements are close to the minimum or maximum indicated on the size prediction table, select two sizes for try-on. For example, if the individual's height is 5 feet 8 inches and his chest is 40 inches, try the 40 short and 40 regular models.

Table 3-4 Size Prediction Table For Men's Coats.

| Chest (Inches) | Height | | | | |
|-------------------|-----------|-----------|----------------|------------|-----------|
| | 5'0"-5'5" | 5'5"-5'8" | 5'8"-5'11" | 5'11"-6'2" | 6'2"-Up |
| 33 | 34XS (P) | *33S (P) | 32R 33R (P) | 33L (P) | ... |
| 34 | 35XS | 34S | 34R (P) | 34L (P) | ... |
| 35 | *36XS | 35S | 35R | 35L (P) | ... |
| 36 | *37XS | 36S | 36R | 36L | 36XL (P) |
| 37 | *38XS | 37S | 37R | 37L | 37XL |
| 38 | *39XS | 38S | 38R | 38L | 38XL |
| 39 | *40XS | 39S | 39R | 39L | 39XL |
| 40 | *41XS (P) | 40S | 40R | 40L | 40XL |
| 41 | *42XS (P) | 41S | 41R | 41L | *41XL (P) |
| 42 | ... | 42S | 42R | 42L | *42XL |
| 43 | ... | 43S | 43R | 43L | *43XL |
| 44 | ... | 44S | 44R | 44L | *44XL |
| 45-46 | ... | 46S (P) | 46R | 46L | ... |
| 47-48 | ... | *48S (P) | *48 | 48L | ... |

*Supplemental sizes which will be stocked at reception stations and key depots only.

(P) = Phase-out item size only.

(d) Alterations.

1Collar. Raising or lowering of the collar consists of ripping out the seams on the bottom of the collar at the neckline, repositioning the collar on the back of the coat to the desired height, resewing the collar, and pressing. Collars must not be raised or lowered over 1/4-inch.

2Shoulders. Uneven shoulder height may cause wrinkles or folds in the back of the coat. They can be removed by raising or lowering the coat shoulders, or by adding to, or removing the shoulder padding.

3Sleeves. When lengthening or shortening the sleeves, measure and mark each sleeve individually. One and one-half inches of outlet material is provided for lengthening the sleeves.

4Side Seams. Taking in or letting out of the side seams should be done only after the next larger or smaller size has been tried.

5Button Alignment. Adjust button(s) on front to straighten their appearance as required. The front buttons may be repositioned 1/4-inch for further refinement of fit.

6Hollow under neck due to very large shoulder muscles or prominent shoulder bone. Let out center seam of back one-quarter of an inch from the top of the center back seam to the waistline.,

7Decrease or increase (where material permits) chest by altering side seams and reshaping armhole, not to alter original appearance and not by moving buttons in the front.

TM 10-227

8Wrinkles at chest with tight armholes. Let out center seam of the back from neck to center back waistline. The amount that neck increases at the center back shall be removed from the shoulder seam at the neck. Let out side seam of front to above the waistline.

9Too much chest fullness due to flat chest. Decrease front chest by taking in front underarm side seam, reshaping armhole in front and back.

10Decrease (excessive material) or increase (where material permits) across the back by adjusting center seam of back vent.

11Decrease front overlap, cut front edge of coat to give straight appearance. Restitch seams. On fusible coats, the excess material may be removed at the front side body seam.

12Decrease shoulders and reset sleeves by removing sleeves and removing extra material in shoulder, then reset sleeves.

13Tack corner edge of top pockets as required.

14Adjust button on shoulder loop.

15Increase left vent overlap (where material permits).

(4) *Cap, Garrison.*

(a) Measurement. Place tape snugly around the largest part of the head, across the forehead and over temples, parallel to the ground.

(b) Selection of initial try-on size. Use the individual's actual measurement and refer to size prediction table 3-5.

(c) Alterations. Altering of the garrison cap is not authorized.

Table 3-5 Size Prediction Table For Men's Caps.

| Head Measurement (Inches) | Cap Size |
|------------------------------|----------|
| 20 1/8 | 6 3/8 |
| 20 1/2 | 6 1/2 |
| 20 7/8 | 6 5/8 |
| 21 1/4 | 6 3/4 |
| 21 5/8 | 6 7/8 |
| 22 | 7 |
| 22 3/8 | 7 1/8 |
| 22 3/4 | 7 1/4 |
| 23 1/8 | 7 3/8 |
| 23 1/2 | 7 1/2 |
| 23 7/8 | 7 5/8 |
| 24 1/4 | 7 3/4 |
| 24 5/8 | 7 7/8 |

(5) *All Weather Coat.*

(a) SubGarments. The subgarments for the chest measurement are the undershirt and dress shirt. Subgarments for the all weather coat try-on are the undershirt, shirt, trousers and coat.

(b) Measurements. The chest and height measurement are needed to select try-on size and model.

(c) Selection of Try-On Garment. Attach all weather coat line for try-on purposes. Using the individual's height and chest measurements, refer to size prediction table 3-6 for size of the initial try-on garment. If the individual's measurements are close to the minimum or maximum indicated on the size prediction table, select two sizes for try-on. For example, if the individual's height is 5 feet, 11 inches, and his chest measurement is between 43 and 45 inches, try-on both the 44 regular and 44 long to get the proper length garment. If the individual's height is 5 feet, 10 inches with a chest measurement of 43 inches, try-on both the 42 regular and 44 regular. In either case, if the selected garment does not fit, try-on additional garments until the best fit is achieved prior to making alterations.

Table 3-6 Size Prediction Table For The All Weather Coat For Male Personnel.

| Chest (Inches) | Height | | | | |
|-------------------|-----------|-----------|------------|-------------|---------|
| | 5'0"-5'5" | 5'5"-5'8" | 5'8"-5'11" | 5'11"-6' 2" | 6'2"-Up |
| 29-31 | ... | 30S | 30R | ... | ... |
| 31-33 | 32XS | 32S | 32R | 32L | ... |
| 33-35 | 34XS | 34S | 34R | 34L | 34XL |
| 35-37 | 36XS | 36S | 36R | 36L | 36XL |
| 37-39 | 38XS | 38S | 38R | 38L | 38XL |
| 39-41 | 40XS | 40S | 40R | 40L | 40XL |
| 41-43 | 42XS | 42S | 42R | 42L | 42XL |
| 43-45 | ... | 44S | 44R | 44L | 44XL |
| 45-47 | ... | 46S | 46R | 46L | 46XL |
| 47-48 | ... | ... | 48R | 48L | 48XL |

(d) Alterations. The only alterations authorized are the shortening of the sleeves and adjustment of the raincoat length. When shortening the sleeves, measure and mark each sleeve individually.

e. Final Check for Proper Concept of Fit. While the individual is wearing the entire uniform (Figs. 3-1 and 3-2), check the following points:

(1) *Shirt (Short or Long Sleeve).* Completely button shirt, including the cuffs of the long sleeve shirt, and check the following points:

(a) Chest and Shoulders. There must be enough room around the chest and shoulders to allow free use of the arms without discomfort.

(b) Collar. The collar should fit snugly enough to give a neat appearance, but not snug as to be uncomfortable.

(c) Sleeves. The sleeves of the long sleeve shirt must fall to the lower part of the wristbone.

TM 10-227

(2) *Trousers.*

(a) Crotch. Check to see that the crotch of the trouser has sufficient ease to allow enough comfort for the soldier. The properly fitted crotch in a trouser will exhibit no vertical breaks, display no drooping or appear to have a tight binding effect to the wearer.

(b) Length. The trousers must hang straight from the seat so the bottom of the front crease of the trousers will reach the top of the instep and be cut on a diagonal line to reach a point approximately midway between the top of the heel and the top of the standard shoe in the back. The trousers may have a slight break in the front.

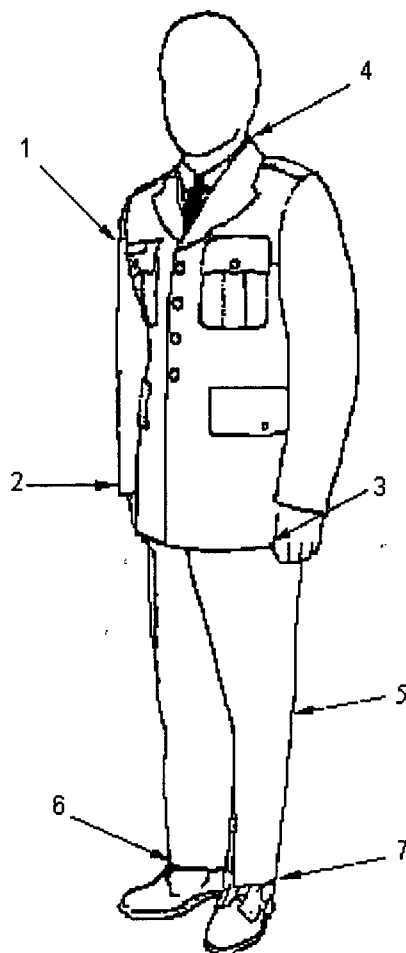

1. Coat fits easily over chest and shoulders.

2. Sleeves fall 1 inch below bottom of wristbone, covering the shirt sleeve.

3. Bottom edge of coat extends below crotch (approximately to the tip of the thumb).

4. Shirt collar shows at least 1/4-inch to 1/2-inch above coat collar at the center back of the coat.

5. The trousers may have a slight break in the front.

6. The bottom of the front crease of the trousers will reach the top of the instep and be cut on a diagonal.

7. Back edge of the trousers will fall approximately midway between the top of the heel and the top of the standard shoe in the back.

Figure 3-1. Fit of Men's Uniform Coat and Trousers.

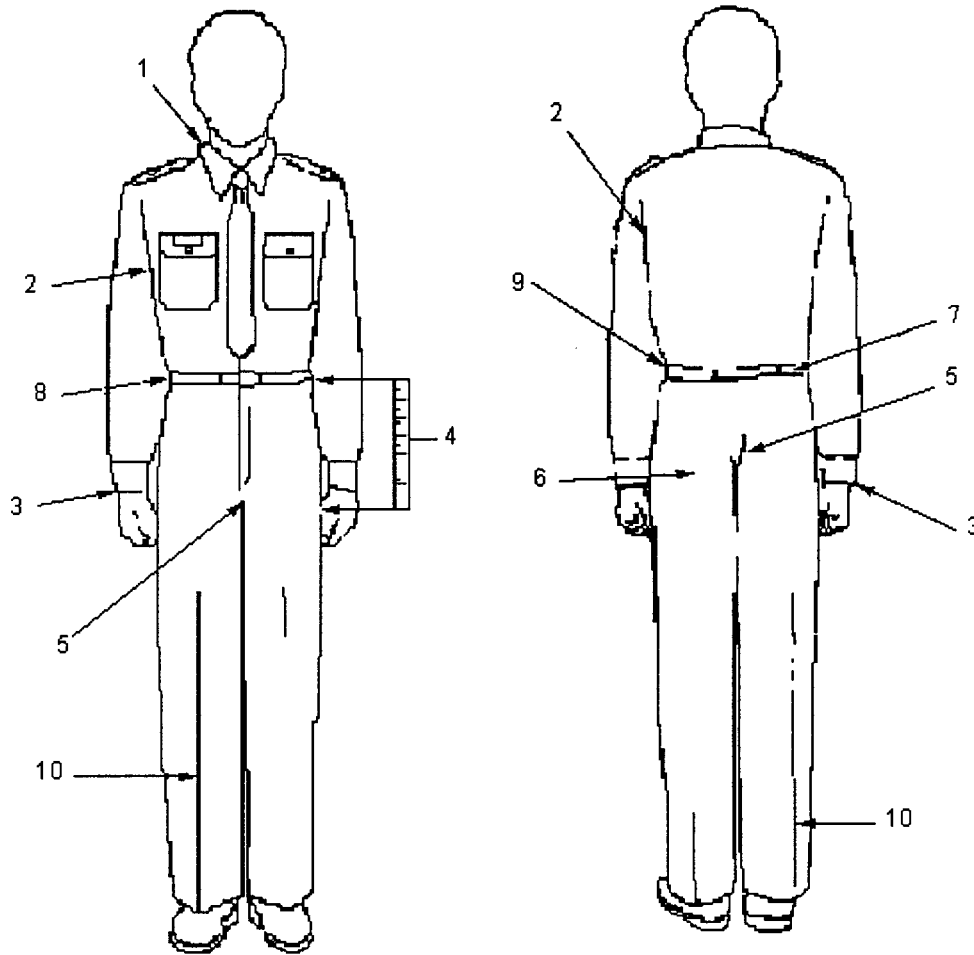

1. Collar fits snugly but not uncomfortably.

2. Fits easily over back and chest allowing free use of the arms.

3. Sleeves fall to lower part of the wristbone.

4. Rise should fit without looseness or constriction.

5. Crotch must have slight ease.

6. Seat must be an easy fit; no wrinkles below back waist.

7. Waist must have about 1/2-inch of ease.

8. Waistband bottom is at top hipbone, plus or minus 1/2-inch.

9. Waist measure must be taken over shirt snug, not tight.

10. Trousers crease must hang straight, not twisted. The trousers may have a slight break in the front.

Figure 3-2. Fit of Men's Shirt and Trousers.

(c) Rise. Make sure the bottom of the trouser waistband is at the top of the hipbone, plus or minus 1/2-inch, and the trousers are well up into the crotch. A short rise may cause tightness and discomfort and a long rise may cause trousers to be baggy in the seat and crotch.

(d) Seat. The trousers must fit easily around the seat without wrinkles below the backwaist. They must be full enough around the hips to prevent the side pockets from spreading and to allow for comfort in normal movements, such as sitting, climbing stairs and walking. When deciding which of two sizes is more suitable, select the trousers that provide the best fit around the seat, even though an alteration at the waist may be required.

(e) Waist. The trousers must be fitted with about a 1/2-inch of ease, fitting easily around the natural waist without bulging.

(3) *Coat*. Completely button coat and inspect for proper concept of fit by checking the following:

(a) Collar. The shirt collar must show about 1/4 to 1/2 inch above the coat collar at the center back of the coat. The coat collar should fit close around the neck without gapping or overlapping.

(b) Back, Shoulders, and Chest. The coat must fit easily over the chest and shoulders, giving a slight draped effect in the front and back. Four to seven inches of looseness should be equally distributed around circumference of the waist to provide comfort when moving.

(c) Hips. Coat fronts should be smooth and even at the bottom edges. The bottom edges in the front of the coat will protrude and the back vent will spread if the coat is too snug at the waist and hips.

(d) Lengths. The bottom edge of the coat must extend below the crotch but not less than one inch. Have the individual stand erect with his arms at his side and bend his fingers at the knuckle, forming a semi-fist and keeping his thumbs straight. The bottom edge of the coat should fall into the pocket made by bending his fingers, approximately to the tip of this thumb.

(e) Sleeves. The sleeves of the coat should fall about 1-inch below the bottom of the wristbone, covering the sleeves of the shirt.

(4) *Cap, Garrison*. The cap (Fig. 3-3) should fit with the bottom of the front vertical crease at the center of the forehead in a straight line with the nose and at a point between 1 and 1-1/2 inches above eyebrow level.

(5) *All Weather Coat*. To ensure proper concept of fit, attach liner and completely button the coat (Fig. 3-4), checking the points:

(a) Collar. The collar of the coat should fit close at the neck without gapping or overlapping. The back of the collar should cover the collars of all subgarments.

(b) Back, Shoulders, and Chest. The coat, with liner attached, must fit easily and comfortably over the shoulders and chest to allow free use of the arms without pulling or giving discomfort to the wearer.

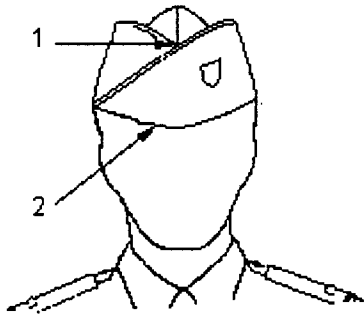

A. GARRISON CAP

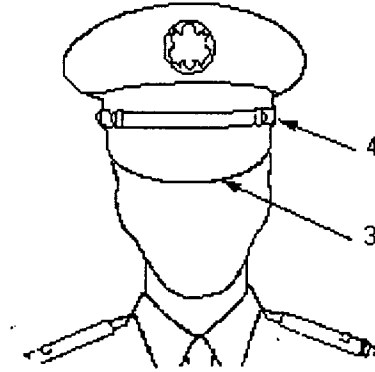

B. SERVICE CAP

(Authorized for optional purchase and wear)

1. Bottom of vertical crease at center of forehead in straight line with nose and between 1 and 1 1/2 inches above eyebrow level.

2. Cap tipped slightly to the wearer's right.

3. Visor positioned so as not to interfere with vision nor ride up on forehead.

4. Braid band creates straight line around head, parallel to ground.

Figure 3-3. Proper Fit of Cap.

(c) Hips. The coat must hang freely from the shoulders without waist suppression or tightness around the hips.

(d) Length. The coat should fall approximately 1 1/2 inches below the mid-point of the knee.

(e) Sleeves. The coat sleeves must be 1/2-inch longer than the green coat and cover the sleeves of all subgarments.

(f) Belt. The belt shall be at natural waistline.

f. Video. Individuals may refer to the video entitled "Proper Fit of Army Green Uniform", distributed to each reception center by US Army Natick RD&E Center, to further clarify fitting procedures.

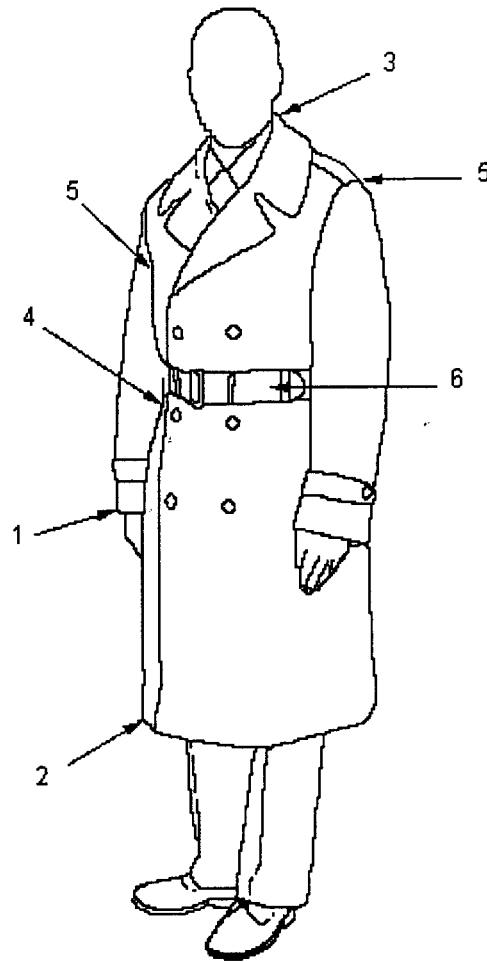

1. Sleeves cover all subgarment sleeves by 1/2 inch.

2. Length falls about 1-1/2 inches below the midpoint of the knee.

3. Back of collar covers all subgarment collars without gapping.

4. Coat hangs freely without waist suppression.

5. Coat must fit easily and comfortably over the shoulders and chest, allowing free use of arms.

6. Belt at natural waistline.

Figure 3-4. Proper Fit of Men's All Weather Coat.

THIS PAGE INTENTIONALLY LEFT BLANK

CHAPTER 4

FITTING OF WOMEN'S UNIFORMS

4-1. WOMEN'S UNIFORM ITEMS. The Women's Green Service Uniform is composed of an Army Green Shade 489 Coat, Skirt or Slacks, an Army Green 415 long or short sleeve shirt, neck tab, and the Cap, Garrison. A Coat, All Weather, Black Shade 385 may be worn over the uniform.

a. Design.

(1) *Coat.* The coat is a fitted, plain edge, single breasted, below hip length coat design with four-button front closure, center back vent, front bust seams from shoulder to top of pockets, slanted flap pockets, open notch collar, long two-piece sleeves, and button-down shoulder loops.

(2) *Skirt.* The skirt is a dress type with a one-piece waistband with rubberized track, a back zipper with two button closure, a back open pleat, fully lined, an unhemmed bottom and a small front waistband pocket on the right hand side.

(3) *Slacks.* The slacks have straight unhemmed legs, a two-piece waistband with center back outlet for alterability, belt loops, thigh outlet for alterability, rubberized track on waistband, front zipper with fly tab and side pockets.

(4) *Shirt.* The shirt is a tuck-in design with a shirt tail. It has front princess seams, side seams and two buttons on cuffs. Both shirts have the same collar. The shirt is available in both long and short sleeve styles.

(5) *Cap, Garrison.* The cap is a flat-folded cloth cap with side curtains which cross at the front. The top edge of the curtain is furnished with a cord edge braid.

(6) *All Weather Coat.*

(a) All Weather Coat. The all weather coat is a six-button, double-breasted model with a belt. The coat has a convertible collar (button at neck), gun flap, shoulder loops, adjustable sleeve straps, and welt pockets with two inside hanging pockets. The back has a yoke and center vent.

(b) Liner. The detachable liner has button loops at the bottom of each sleeve and a zipper around the edge for attaching the liner to the coat. The coat is fully lined.

(7) *Neck Tab.* The neck tab is one-piece with two pointed ends and a hook and loop adjustment closure strap.

b. Material.

(1) *Coat, Skirt, Slacks and Garrison Cap* Polyester/wool serge, 11.5 oz. Army Green 489.

(2) *Shirts.* Precured durable press 65/35 polyester/cotton broadcloth, stock dyed yarn in end-on-end configuration, 3.8-4.3 ounce Army Green 415.

(3) *All Weather Coat.* 65/35 polyester/cotton poplin. The color is Army Black 385.

(4) *Neck Tab.* Polyester/cotton broadcloth, Army Black 305.

TM 10-227

c. Sizing System.

(1) *Coat.* The coat is available in two size increments from size 6 through 20. The coat is also available in Junior sizes in two size increments from size 5 through 17. Most sizes are available in Short (S), Short-plus (S+), Regular (R), Regular-plus (R+), Long (L), and Long-plus (L+), Extra Short (XS) is available in sizes 9,11,13,15, and 17. Extra Short-plus (XS+) is available in sizes 13+, 15+, and 17+; and Extra Long (XL) is available in size 14.

(2) *Skirt.* The skirts are available in sizes 4 through 26; with 3 hip designations: junior, misses and womens; and 3 height designations: petite, regular and tall. Refer to size prediction chart (table 4-1) for available sizes.

(3) *Slacks.* The skirts are available in sizes 4 through 26; with 3 hip designations: junior, misses and womens; and 3 height designations: petite, regular and tall. Refer to size prediction chart (table 4-1) for available sizes.

(4) *Shirts.*

(a) The long sleeve shirt is available in sizes 4 through 26 and in five sleeve lengths, 29 1/2" ((P) Petite), 31" ((R) Regular), 32 1/2" ((L) Long), 34" ((XL) Extra Long and 35 1/2" ((XXL) Extra Extra Long). Refer to size prediction chart Table 4-1 for available sizes.

(b) The short sleeve shirt is available in sizes 4 through 26 with one sleeve length for all sizes.

(c) The neck tab for the long and short sleeve shirt comes in one size which fits all sizes.

(5) *Cap, Garrison.* The cap is provided in 1/2-inch increments from size 20 through size 25.

(6) *All Weather Coat.* The all weather coat is provided in numerical sizes, with two size increments from size 6 through 20 and is available in three lengths; Short (S), Regular (R) and Long (L).

d. General Fitting Procedures.

(1) *Shirt.*

(a) *Subgarments.* Subgarments for the shirt try-on are the items of undergarments normally worn (bra).

(b) *Measurements.* The bust, waist and sleeve lengths are required for proper size and model try-on garment. (Refer to Fig. 4-1a through h for proper measurement procedures.)

(c) *Selection of Try-on Garment.* Use the individual's bust, waist and sleeve length measurements and refer to the size prediction chart (table 4-1), for the selection of initial try-on size. For the long sleeve shirt, measure from the middle of the back of the individual's neck, down the arm, over the slightly bent elbow to the center of the wrist bone. Refer to Fig. 4-1h for the proper procedures.

(d) *Alterations.*

1 *Front Princess and Side Seams.* The women's shirts can be tapered in the front by taking in the front princess seams and side seams. When fitting extremely broad shouldered women, it may be necessary to select a shirt one or two sizes larger than indicated and take in the side and front princess seams.

2 *Sleeves.* Shortening of the shirt sleeves is acceptable for the long sleeve shirt only. The buttons on cuffs may be set over. Utilize both buttons to obtain the concept of fit prior to altering sleeve lengths.

(2) *Skirt.*

(a) Subgarments. Subgarments for the skirt try-on are a bra, panties, hosiery, the shirt and the oxford shoes.

(b) Measurements. The waist, hip, and height measurements are required for proper size and model try-on garment. (Refer to Fig. 4-1 a through g for proper measurement procedures.)

(c) Selection of Try-on Garment. Use the individual's waist, hip, and height measurements and refer to the size prediction chart (table 4-1) for the selection of the initial try-on size. The hip measurement will determine if a Junior (J), Misses (M), or Womens (W) size is required, and the height measurement determines the length of the skirt.

(d) Alterations.

1 Hips, Waist and Waistband. Seams and waistband may be altered to hip and waist size as long as the skirt balance is maintained.

2 Length. The Skirt Length may be altered to desired length by adjusting the skirt hem. The finished hem should be uniform and 2 1/2 to 3 inches wide.

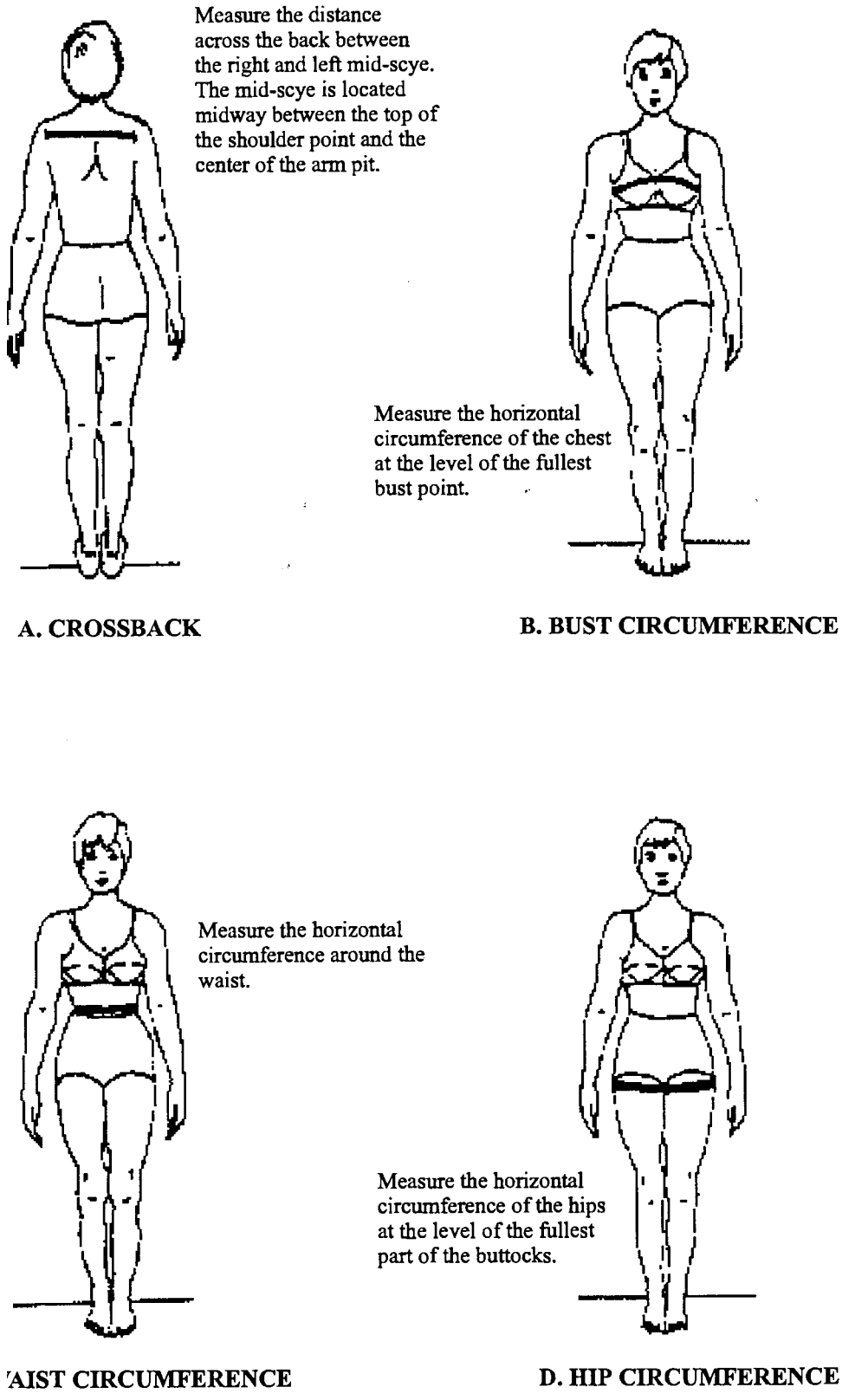
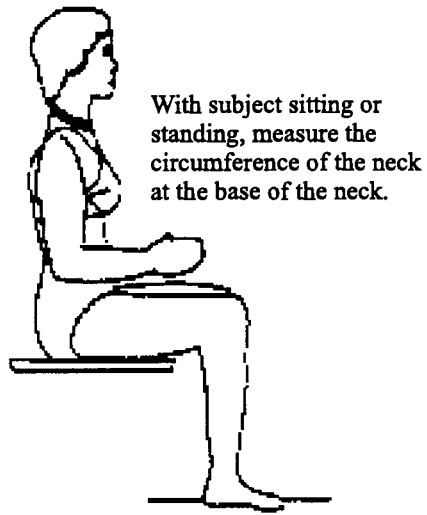
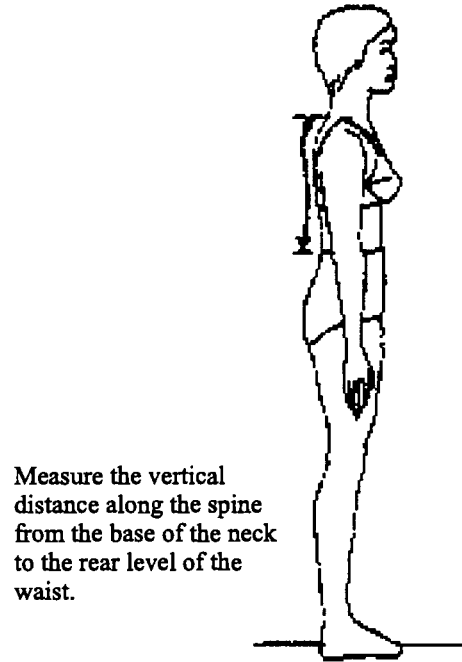

Figure 4-1. Body Size Prediction Chart Measurement Diagrams



E. NECK



F. BACKWAIST LENGTH

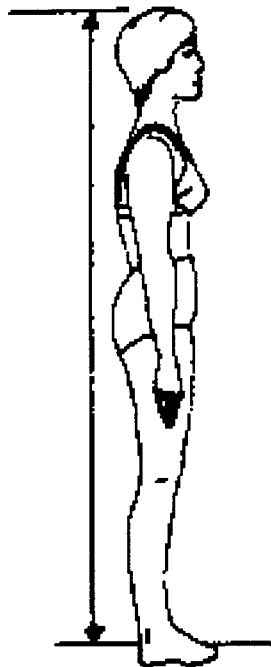

G. HEIGHT

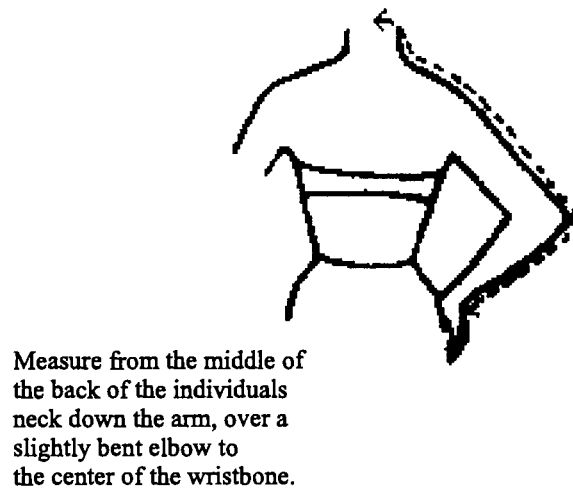

H. SLEEVE LENGTH

Figure 4-1. Body Size Prediction Chart Measurement Diagrams (Continued).

TM 10-227

(3) *Slacks.*

(a) Subgarments. Subgarments for the slacks try-on are a bra, panties, hosiery, the skirt, and the oxford shoes.

(b) Measurements. The waist, hip and height measurements are required for proper size and model try-on garment. (Refer to Fig. 4-1a through g for proper measurement procedures).

(c) Selection of Try-on Garment. Use the individual's waist, hip and height measurements and refer to the size prediction chart (table 4-1), for selection of the initial try-on size. The hip measurement will determine if a Junior (J), Misses (M), or Womens (W) size is required, and the height measurement determines the length of the slacks.

(d) Alterations.

1 Waist and Waistband. The waistband and darts may be altered as long as the slack balance is maintained. The two piece waistband has a center back outlet which can be opened and allows the slacks to be taken in or let out without having to remove the waistband.

2 Length. Measure and mark both slack legs individually. No more than a two inch turn up is permissible. The front crease of the slacks will reach the top of the instep and be cut on a diagonal line to reach a point approximately midway between the top of the heel and the top of the oxford shoe in the back. The slacks may have a slight break in the front.

3 Hip and Seat. Let out or take in at the back outlet to adjust hip and seat sides. The side seams may be adjusted to hip size. Side seams must be centered at the sides and hang straight to the bottom. Note that if the seat needs to be altered, the crotch of the slacks must also be altered.

4 Crotch and Thighs. The crotch and thigh seams have an outlet. The outlet may be used to let out or take in the crotch and thigh areas to improve fit while maintaining the balance of the slacks.

(4) *Coat.*

(a) Subgarments. Subgarments for the coat try-on are a bra, panties, hosiery, slacks or skirt, and the long sleeve shirt.

(b) Measurements. The bust, waist, hip, crossback, and backwaist length measurements are required for proper size and model try-on garment. (Refer to Fig 4-1a through g for proper measurement procedures.)

(c) Selection of Try-on Garment. Use the individual's bust, waist, hip, crossback, and backwaist length measurements and refer to the size prediction chart (table 4-1) for selection of the initial try-on size. The waist and hip measurements will determine if a regular (R) or a plus (+) size coat is required. The backwaist length will determine the length of the coat. Junior coats have shorter backwaist length.

(d) Alterations.

1 Hem line. The coat hem line may be shortened no more than 1 inch. Shortening is authorized only when the coat is out of proportion to the individual's height. For example, if a short woman requires a regular length to fit her backwaist length, the coat will require shortening so the length is correctly proportioned for her height.

2 Backwaist Length. The waistline may be raised or lowered by adjusting the side-back seams.

3 Bust. The front bust seam may be taken in and front side body seams let out or taken in .

4 Waist. Waist may be tapered or let out at side-front and side-back seams.

5 Hip. Side-back seams may be adjusted to hip size, as long as the balance is maintained.

6 Shoulders. The coat shoulders may be raised or lowered by adding or removing shoulder pads.

7 Sleeves. The sleeves may be adjusted to reach a point one inch below the bottom of the wristbone. The sleeves of the green shirt should not show below the coat sleeves.

8 Collar. In cases of long or short necks, raising or lowering the collar improves fit and appearance. This alteration consists of ripping out the seams on under and top collar, repositioning the collar or the back of the coat for the desired length, resewing the collar and pressing. The collar must not be raised or lowered over 1/4-inch.

9 Button Alignment. The position of the buttons on the front of the coat may be adjusted no more than 1/4-inch to improve the front closure, as long as the row of buttons is straight from the top to bottom when buttoned, and the coat balance is maintained.

(5) *Cap, Garrison*. Actual head measurement (in inches) correlates to cap size. To measure for head size, hold the tape measure snugly around the largest part of the head across the forehead, and over the temple parallel to the ground. The woman's hair should be the length and style in which it will usually be worn. Alteration of the cap is not authorized.

(6) *All Weather Coat*.

(a) Subgarments. The Green Service Uniform with skirt is worn as the subgarment for the all weather coat try-on.

(b) Measurements. The bust and height measurements are required. (Refer to Fig. 4-1a through g for proper measurement procedures.)

(c) Selection of Try-on Garment. Using the bust and height measurements taken over the Service Uniform, refer to size prediction chart (table 4-1) for the size of the initial try-on garment. If the individual's measurements are close to the minimum or maximum indicated on the size prediction chart, select two sizes for try-on.

(d) Alterations.

1 Hem line. The all weather coat hem line may be adjusted to about one inch longer than the skirt worn under it but not more than three inches below the midpoint of the knee (Fig. 4-4).

2 Sleeves. The coat may be shortened or lengthened so sleeves will be about one inch longer than the sleeves of the Army Green 489 uniform coat. When shortening the sleeves, measure and mark each sleeve individually. The sleeves of the liner can only be shortened.

3 Button Alignment. The position of the buttons on the front of the all weather coat may be adjusted no more than 1/4-inch to improve the front closure as long as the row of buttons is straight from the top to bottom when buttoned, and the coat balance is maintained.

e. Final Check for Proper Concept of Fit. The uniform is designed to fit the figure easily with smooth tailored lines.

TM 10-227

(1) *Shirt*. Completely button shirt, including cuffs of the long sleeve shirt, and check the following points:

(a) Collar. The shirt collar should fit the neck without bulging (Fig. 4-2).

(b) Back and Shoulders. The shirt should fit smoothly across the back and shoulders (Fig. 4-2) without tightness or wrinkles. Ease across back should be approximately 2 1/2 inches. There must be enough room around back and shoulders to allow free use of arms without discomfort.

(c) Bust. The shirt should fit over the bust without strain (Fig. 4-2) or gaping between buttons. There shall be 2 1/2 inches of ease at front. This shall be determined by pinching 1 1/4 inches excess cloth on the double on shirt front.

(d) Hips and Waist. The shirt should fit easily over the hips conforming to the waistline curve with minimal blousing. Ease at the waist should be 2 1/2 inches at each side seam. This shall be determined by pinching 1 1/4 inches excess cloth on the double at waist. The shirt front, below the waist, should overlap without pulling or gaping.

(e) Sleeves.

1 Short Sleeve. The shirt is designed so that if the shirt size is correct in other areas, the sleeves will be correctly proportioned.

2 Long Sleeve. The sleeve length should reach below the lower part of the wristbone (Fig. 4-2).

(2) *Skirt*. The skirt viewed from the front and back should continue the slender lines of the coat, tapered slightly at the sides.

(a) Waist and Hips. The skirt should fit snugly at the waist and smoothly over the hips so that it does not drape in folds. The center of the skirt waistband should be at the natural waistline.

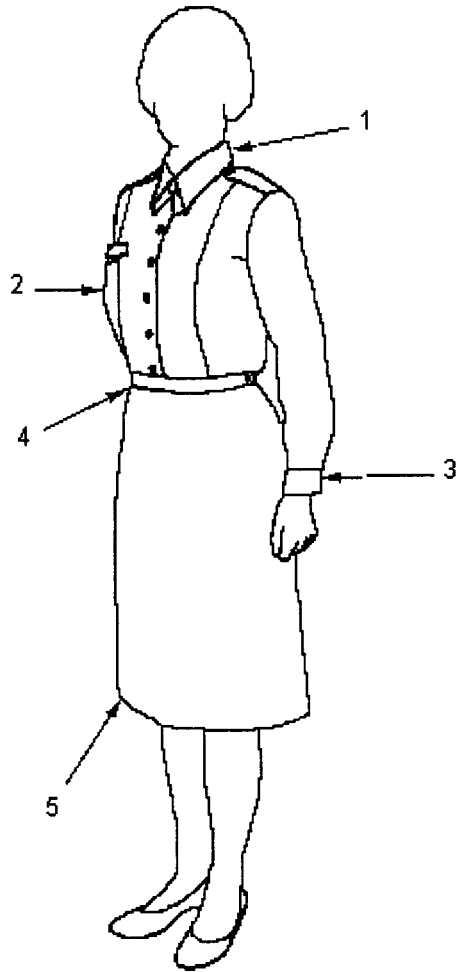

1. Collar should fit without bulging.

2. Shirt should fit over the bust without strain.

3. For the long sleeve shirt, length should reach below the lower part of the wristbone.

4. The skirt should fit snugly at the waist and smoothly over the hips.

5. Skirt should fall between one inch above and two inches below the midpoint of the knee.

6. Length of back vent shall not be less than 5 inches long.

Figure 4-2. Fit of Women's Uniform Shirt and Skirt.

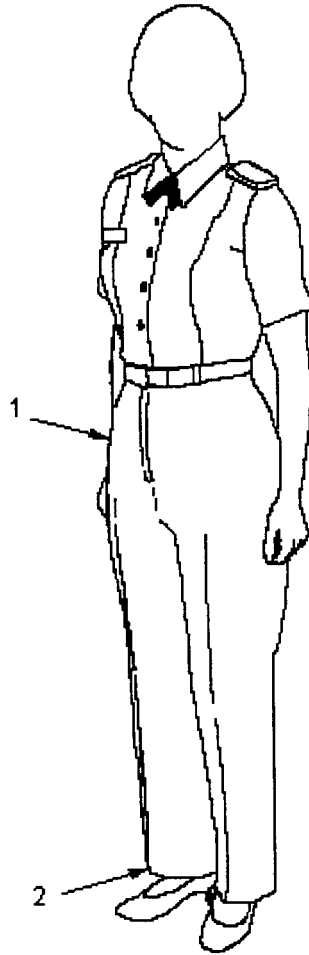

1. Slacks fit snugly at the waist and smoothly over the hips.

2. The bottom of the slacks will reach the top of the instep in the front and reach a point approximately midway between the top of the heel and the top of the oxford shoe in the back.

Figure 4-3. Fit of Women's Uniform Shirt and Slacks.

(b) Length. The skirt length is determined by the individual's height, but must fall somewhere between one inch above and two inches below the mid-point of the knee (Fig. 4-2).

(3) *Slacks.*

(a) Hips and Waist. The slacks must fit snugly at the waist and should have approximately 2 inches of ease over the hips. This shall be determined by pinching 1/2-inch excess cloth on the double on each side. The center of the waistband should be at the natural waistline. (Fig. 4-3). Side pockets must lay flat without bulging.

(b) Length. The bottom of the slacks will reach the top of the instep in the front, and reach a point approximately midway between the top of the heel and the top of the oxford shoe in the back. When wearing the optional pump, this figure may vary slightly depending on heel height (Fig. 4-3).

(c) Crotch. The crotch of the slacks should not bind fit with a slight ease and allow for squatting and bending.

(4) *Coat*. The coat has been designed to look equally well over both slacks and skirt, hence the longer than average length. Completely button the coat before checking the following:

(a) Back and Shoulders. The coat should fit smoothly across the back and shoulders (Fig. 4-4).

(b) Bust. The coat should fit across the bust without strain (Fig. 4-4).

(c) Hips and Waist. The coat should fit easily over the hips and conform to the waistline curve without blousing. The bottom button of the coat should fall approximately one inch below the natural waistline. The coat front, below the waist, must overlap without pulling or gaping so the front of the coat will present a straight line from the top button to the coat hem. The back vent must also overlap without pulling or gaping (Fig. 4-4).

(d) Length. The coat is designed so that if the coat size is correct in other areas, the coat length, with few exceptions, will be correctly proportioned (Fig. 4-4).

(e) Sleeves. The sleeves of the coat should fall about one inch below the bottom of the wristbone (Fig. 4-4). The sleeves of the green shirt should not show beneath the coat sleeves.

(5) *Cap Garrison*. The cap will be worn with the front vertical crease centered on the forehead in a straight line with the nose so that the front lower portion of the cap is approximately one inch above the eyebrows (Fig. 4-4).

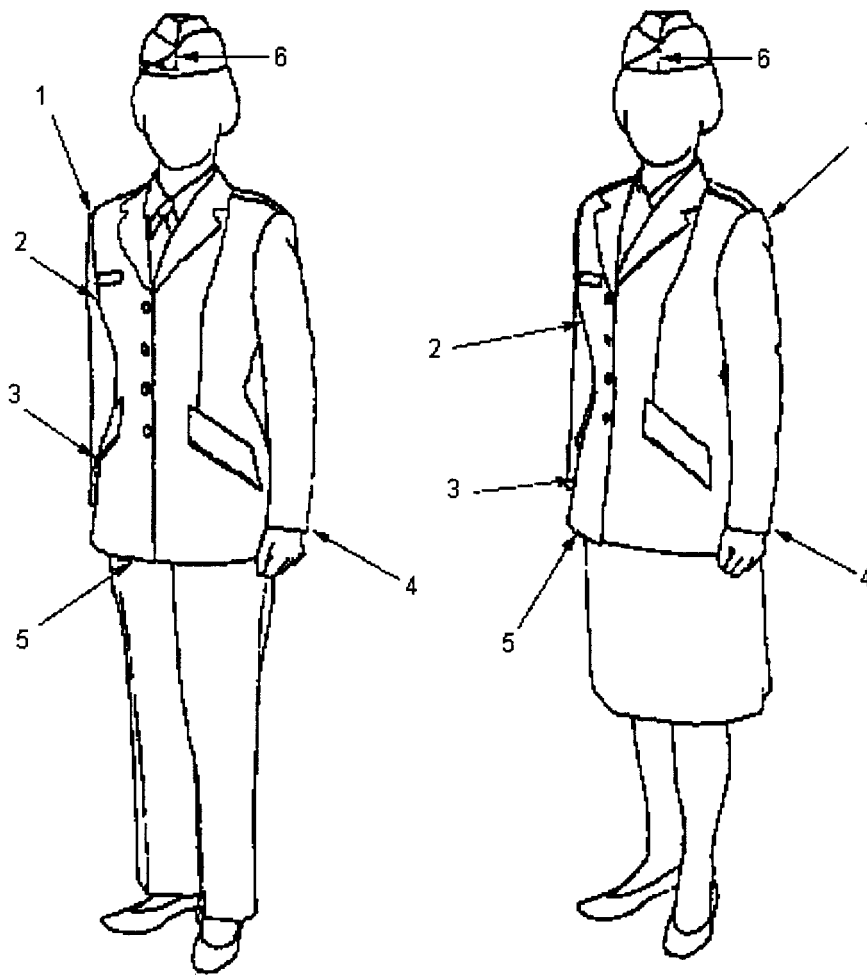

1. Coat fits smoothly across shoulders.
2. Coat fits across bust without strain.
3. Coat fits easily over the hips and conforms to waistline curve without blousing.
4. Sleeves should fall one inch below the bottom of the wristbones.

5. Coat length is determined by individual's backwaist measurement.

6. The cap will be worn with the front vertical crease centered on the forehead in a straight line with the nose so the front lower portion of the cap is approximately one inch above the eyebrows.

Figure 4-4. Fit of Women's Uniform Coat and Slacks/Coat and Skirt.

(6) *All Weather Coat*. To ensure proper concept of fit, attach line and completely button the coat. Check the following points:

(a) Collar. When buttoned, the all weather coat must fit close at the neck without gapping or overlapping. The collar must cover the collar of all subgarments (Fig. 4-5).

(b) Back, Shoulders and Bust. The all weather coat must fit comfortably over the shoulders and bust and lie smoothly across the back. When properly fitted, the all weather coat will allow free use of the arms without pulling or giving discomfort to the wearer (Fig. 4-5)

(c) Hips and Waist. The all weather coat must hang freely from the shoulders without waist suppression or tightness around the hips (Fig. 4-5).

(d) Length. The all weather coat should fall approximately 1-1/2 inches below the midpoint of the knee and must cover the skirt worn under it (Fig. 4-5).

(e) Sleeves. The all weather coat sleeves must be 1/2-inch longer than and cover the sleeves of all subgarments (Fig. 4-5).

(f) Belt. The belt shall be at natural waistline.

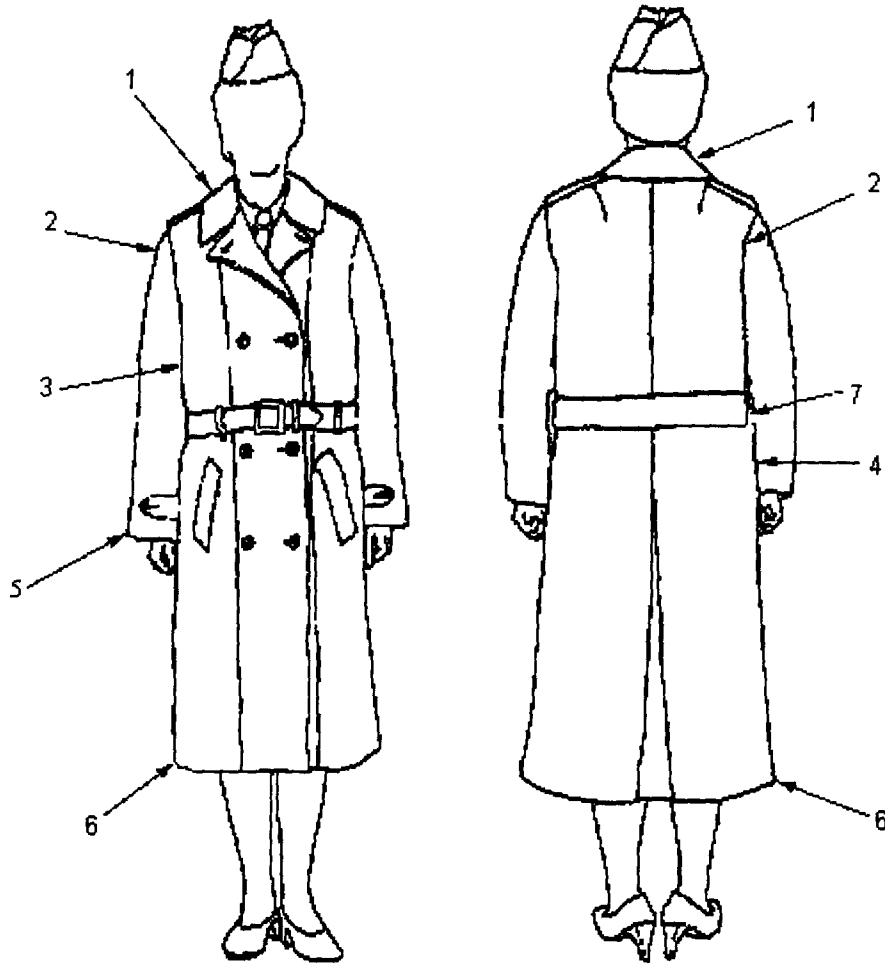

1. Coat collar must cover the collar of all subgarments.
2. Coat fits comfortably across shoulders and smoothly across back.
3. Coat fits comfortably across bust.
4. No waist suppression or tightness around hips.

5. Sleeves must cover all subgarments.
6. Coat must fall approximately 1/2 inch below midpoint of the knee and, when applicable, cover the skirt worn under it.
7. Belt at natural waistline.

Figure 4-5. Fit of Women's All Weather Coat.

Table 4-1. Size Prediction Chart for Women's Items.

SIZE PREDICTION CHART FOR U.S. ARMY WOMEN'S SKIRTS AND SLACKS

| BODY DIMENSIONS | HEIGHT LESS THAN 63" (P) | HEIGHT 63 ½" - 67" (R) | HEIGHT MORE THAN 67" (T) |
|--|-------------------------------------|-----------------------------------|-------------------------------------|
| WAIST LESS THAN 24 ½" HIP LESS THAN 35" | 4MP | 4MR | ***** |
| WAIST - 24 ½" - 25 ½" HIP - 35" - 36" HIP - 36" - 38" | 6MP 6WP | 6MR 6WR | 6MT 6WT |
| WAIST - 25 ½" - 26 ½" HIP - 37" HIP - 37" - 39" | 8MP 8WP | 8MR 8WR | 8MT 8WT |
| WAIST - 26 ½" - 28" HIP - 36 ½" HIP - 36 ½" - 38 ½" HIP - 38 ½" - 40 ½" | 10JP 10MP 10WP | 10JR 10MR 10WR | 10JT 10MT 10WT |
| WAIST - 28" - 29 ½" HIP - 38" HIP - 38" - 40" HIP - 40" - 42" | 12JP 12MP 12WP | 12JR 12MR 12WR | 12JT 12MT 12WT |
| WAIST - 29 ½" - 31" HIP - 39 ½" HIP - 39 ½" - 41 ½" HIP - 41 ½" - 43 ½" | 14JP 14MP 14WP | 14JR 14MR 14WR | 14JT 14MT 14WT |
| WAIST - 31" - 33" HIP - 41 ½" HIP - 41 ½" - 43 ½" HIP - 43 ½" - 45 ½" | 16JP 16MP 16WP | 16JR 16MR 16WR | 16JT 16MT 16WT |
| WAIST - 33" - 35" HIP - 45 ½" HIP - 45 ½" - 47 ½" | ***** ***** | 18MR 18WR | 18MT 18WT |
| WAIST - 35" - 37" HIP - 45 ½" - 47 ½" HIP - 47 ½" - 49 ½" | ***** | 20MR 20WR | ***** |
| WAIST - 37" - 39" HIP - 49 ½" | ***** | 22MR | ***** |
| WAIST - 39" - 41" HIP - 51 ½" | ***** | 24MR | ***** |
| WAIST - 41" - 43" HIP - 53 ½" | ***** | 26MR | ***** |

Table 4-1. Size Prediction Chart for Women's Items (Continued).

**SIZE PREDICTION CHART FOR U.S. ARMY WOMEN'S TUCK-IN SHIRT
LONG SLEEVE AND SHORT SLEEVE**

| BODY DIMENSIONS | SLEEVE LENGTH 29 ½" (P) | SLEEVE LENGTH 31" (R) | SLEEVE LENGTH 32 ½" (L) | SLEEVE LENGTH 34" (XL) | SLEEVE LENGTH 35½"(XXL) | SHORT SLEEVE SHIRT |
|---|--|--------------------------------------|--|---------------------------------------|--|-----------------------------------|
| BUST LESS THAN 32 ½" WAIST LESS THAN 24 ½" | 4P | 4R | 4L | ***** | ***** | 4 |
| BUST - 32 ½" - 33 ½" WAIST - 24 ½" - 25 ½" | 6P | 6R | 6L | ***** | ***** | 6 |
| BUST - 33 ½" - 34 ½" WAIST - 25 ½" - 26 ½" | 8P | 8R | 8L | ***** | ***** | 8 |
| BUST - 34 ½" - 36" WAIST - 26 ½" - 28" | 10P | 10R | 10L | 10XL | 10XXL | 10 |
| BUST - 36" - 37 ½" WAIST - 28" - 29 ½" | 12P | 12R | 12L | 12XL | 12XXL | 12 |
| BUST - 37 ½" - 39" WAIST - 29 ½" - 31" | 14P | 14R | 14L | 14XL | 14XXL | 14 |
| BUST - 39" - 41" WAIST - 31" - 33" | 16P | 16R | 16L | 16XL | 16XXL | 16 |
| BUST - 41" - 43" WAIST - 33" - 35" | 18P | 18R | 18L | 18XL | 18XXL | 18 |
| BUST - 43" - 45" WAIST - 35" - 37" | 20P | 20R | 20L | 20XL | 20XXL | 20 |
| BUST - 45" - 47" WAIST - 37" - 39" | ***** | 22R | ***** | 22XL | 22XXL | 22 |
| BUST - 47" - 49" WAIST - 39" - 41" | ***** | 24R | ***** | 24XL | 24XXL | 24 |
| BUST - 49" - 51" WAIST - 41" - 43" | ***** | 26R | ***** | 26XL | 26XXL | 26 |

Table 4-1. Size Prediction Chart for Women's Items.

SIZE PREDICTION CHART FOR U.S. ARMY WOMEN'S ALL WEATHER COATS

| SIZE | 2 | 3 | 4 | 5 | 6 |
|-------------------|-----------|-----------|-----------|-----------|-----------|
| *HIP TYPE | 0 + | 0 + | 0 + | 0 + | 0 + |
| BUST | 30 | 30 ½ | 31 | 31 ½ | 32 |
| WAIST | 21 ½ 22 ½ | 22 23 | 22 ½ 23 ½ | 23 24 | 23 ½ 24 ½ |
| HIPS | 32 34 | 32 ½ 34 ½ | 33 35 | 33 ½ 35 ½ | 34 36 |
| BACKWAIST: | | | | | |
| X-SHORT | ***** | 12 ¾ | ***** | 13 | ***** |
| SHORT | 14 1/8 | 13 ½ | 14 3/8 | 13 ¾ | 14 5/8 |
| REGULAR | 14 7/8 | 14 1/4 | 15 1/8 | 14 ½ | 15 3/8 |
| LONG | 15 7/8 | 15 1/4 | 16 1/8 | 15 1/4 | 16 3/8 |
| X-LONG | 16 7/8 | ***** | 17 1/8 | ***** | 17 3/8 |
| HEIGHT: | | | | | |
| X-SHORT | ***** | 57 | ***** | 57 ½ | ***** |
| SHORT | 59 | 59 | 59 ½ | 59 ½ | 60 |
| REGULAR | 62 | 62 | 62 ½ | 62 ½ | 63 |
| LONG | 66 | 66 | 66 ½ | 66 ½ | 67 |
| X-LONG | 69 | ***** | 69 ½ | ***** | 70 |

* HIP TYPE - 0 REPRESENTS REGULAR MEASUREMENT, + REPRESENTS PLUS SIZE

Table 4-1. Size Prediction Chart for Women's Items.

**SIZE PREDICTION CHART FOR U.S. ARMY WOMEN'S
ALL WEATHER COATS (Continued)**

| SIZE | 7 | 8 | 9 | 10 | 11 |
|-------------------|-----------|-----------|-----------|-----------|-----------|
| *HIP TYPE | 0 + | 0 + | 0 + | 0 + | 0 + |
| BUST | 32 ½ | 33 | 33 ½ | 34 | 34 ½ |
| WAIST | 24 25 | 24 ½ 25 ½ | 25 26 | 25 ½ 26 ½ | 26 ¼ 27 ¼ |
| HIPS | 34 ½ 36 ½ | 35 37 | 35 ½ 37 ½ | 36 38 | 36 ¾ 38 ¾ |
| BACKWAIST: | | | | | |
| X-SHORT | 13 ¼ | ***** | 13 ½ | ***** | 13 ¾ |
| SHORT | 14 | 14 7/8 | 14 ½ | 15 1/8 | 14 ½ |
| REGULAR | 14 ¾ | 15 5/8 | 15 | 15 7/8 | 15 ¼ |
| LONG | 15 ½ | 16 5/8 | 15 ¾ | 16 7/8 | 16 |
| X-LONG | ***** | 17 5/8 | ***** | 17 7/8 | ***** |
| HEIGHT: | | | | | |
| X-SHORT | 58 | ***** | 58 ½ | ***** | 59 |
| SHORT | 60 | 60 ½ | 60 ½ | 61 | 61 |
| REGULAR | 63 | 63 ½ | 63 ½ | 64 | 64 |
| LONG | 67 | 67 ½ | 67 ½ | 68 | 68 |
| X-LONG | ***** | 70 ½ | ***** | 71 | ***** |

* HIP TYPE - 0 REPRESENTS REGULAR MEASUREMENT, + REPRESENTS PLUS SIZE

Table 4-1. Size Prediction Chart for Women's Items (Continued).

**SIZE PREDICTION CHART FOR U.S. ARMY WOMEN'S
ALL WEATHER COATS (Continued)**

| SIZE | 12 | 13 | 14 | 15 | 16 |
|-------------------|-----------|---------------|-----------|---------------|-----------|
| *HIP TYPE | 0 + | 0 + | 0 + | 0 + | 0 + |
| BUST | 35 ½ | 36 1/4 | 37 | 37 3/4 | 38 ½ |
| WAIST | 27 28 | 27 3/4 28 3/4 | 28 ½ 29 ½ | 29 1/4 30 1/4 | 30 31 |
| HIPS | 37 ½ 39 ½ | 38 ½ 40 ½ | 39 41 | 39 3/4 41 3/4 | 40 ½ 42 ½ |
| | | | | | |
| BACKWAIST: | | | | | |
| X-SHORT | ***** | 14 | ***** | 14 1/4 | ***** |
| SHORT | 15 3/8 | 14 3/4 | 15 5/8 | 15 | 15 7/8 |
| REGULAR | 16 1/8 | 15 ½ | 16 3/8 | 15 3/4 | 16 5/8 |
| LONG | 17 1/8 | 16 ½ | 17 3/8 | 16 ½ | 17 5/8 |
| X-LONG | 18 1/8 | ***** | 18 3/8 | ***** | 18 5/8 |
| | | | | | |
| HEIGHT: | | | | | |
| X-SHORT | ***** | 59 ½ | ***** | 60 | ***** |
| SHORT | 61 ½ | 61 ½ | 62 | 62 | 62 ½ |
| REGULAR | 64 ½ | 64 ½ | 65 | 65 | 65 ½ |
| LONG | 68 ½ | 68 ½ | 69 | 69 | 69 ½ |
| X-LONG | 71 ½ | ***** | 72 | ***** | 72 ½ |

* HIP TYPE - 0 REPRESENTS REGULAR MEASUREMENT, + REPRESENTS PLUS SIZE

Table 4-1. Size Prediction Chart for Women's Items (Continued).

**SIZE PREDICTION CHART FOR U.S. ARMY WOMEN'S
ALL WEATHER COATS (Continued)**

| SIZE | 17 | 18 | 19 | 20 |
|-------------------|---------------|---------------|---------------|---------------|
| *HIP TYPE | 0 + | 0 + | 0 + | 0 + |
| BUST | 39 1/4 | 40 1/2 | 40 3/4 | 42 1/2 |
| WAIST | 30 3/4 31 3/4 | 32 33 | 32 1/4 33 1/4 | 34 35 |
| HIPS | 41 1/4 43 1/4 | 42 1/2 44 1/2 | 42 3/4 44 3/4 | 44 1/2 46 1/2 |
| | | | | |
| BACKWAIST: | | | | |
| X-SHORT | 14 1/2 | ***** | 14 3/4 | ***** |
| SHORT | 15 1/4 | 16 1/8 | 15 1/2 | 16 3/8 |
| REGULAR | 16 | 16 7/8 | ***** | 17 1/8 |
| LONG | 16 3/4 | 17 7/8 | ***** | 18 1/8 |
| X-LONG | ***** | 18 7/8 | ***** | 19 1/8 |
| | | | | |
| HEIGHT: | | | | |
| X-SHORT | 60 1/2 | ***** | 61 | ***** |
| SHORT | 62 1/2 | 63 | 63 | 63 1/2 |
| REGULAR | 65 1/2 | 66 | 66 | 66 1/2 |
| LONG | 69 1/2 | 70 | 70 | 70 1/2 |
| X-LONG | ***** | 73 | ***** | 73 1/2 |

* HIP TYPE - 0 REPRESENTS REGULAR MEASUREMENT, + REPRESENTS PLUS SIZE

Table 4-1. Size Prediction Chart for Women's Items.

SIZE PREDICTION CHART FOR WOMEN'S DRESS COAT

| SIZE | BUST | | | WAIST | | | HIP | | | BACK WAIST | | |
|------|--------|--------|--------|--------|--------|--------|--------|--------|--------|------------|--------|--------|
| | J | M | W | J | M | W | J | M | W | P | R | T |
| 4 | ---- | 32-1/2 | ---- | ---- | 24-1/2 | ---- | ---- | 35 | ---- | 14-3/8 | 15-1/8 | ---- |
| 6 | ---- | 33-1/2 | 33-1/2 | ---- | 25-1/2 | 26 | ---- | 36 | 38 | 14-5/8 | 15-3/8 | 16-3/8 |
| 8 | ---- | 34-1/2 | 34-1/2 | ---- | 26-1/2 | 27 | ---- | 37 | 39 | 14-7/8 | 15-5/8 | 16-5/8 |
| 10 | 36 | 36 | 36 | 27-1/2 | 28 | 28-1/2 | 36-1/2 | 38-1/2 | 40-1/2 | 15-1/8 | 15-7/8 | 16-7/8 |
| 12 | 37-1/2 | 37-1/2 | 37-1/2 | 29 | 29-1/2 | 30 | 38 | 40 | 42 | 15-3/8 | 16-1/8 | 17-1/8 |
| 14 | 39 | 39 | 39 | 30-1/2 | 31 | 31-1/2 | 39-1/2 | 41-1/2 | 43-1/2 | 15-5/8 | 16-3/8 | 17-3/8 |
| 16 | 41 | 41 | 41 | 32-1/2 | 33 | 33-1/2 | 41-1/2 | 43-1/2 | 45-1/2 | 15-7/8 | 16-5/8 | 17-5/8 |
| 18 | ---- | 43 | 43 | ---- | 35 | 35-1/2 | ---- | 45-1/2 | 47-1/2 | ---- | 16-7/8 | 17-7/8 |
| 20 | ---- | 45 | 45 | ---- | 37 | 37-1/2 | ---- | 47-1/2 | 49-1/2 | ---- | 17-1/8 | ---- |
| 22 | ---- | 47 | | ---- | 39 | --- | ---- | 49-1/2 | ---- | ---- | 17-3/8 | ---- |
| 24 | ---- | 49 | | ---- | 41 | ---- | ---- | 51-1/2 | ---- | ---- | 17-5/8 | ---- |
| 26 | ---- | 51 | | ---- | 43 | ---- | ---- | 53-1/2 | ---- | ---- | 17-7/8 | ---- |

THIS PAGE INTENTIONALLY LEFT BLANK

CHAPTER 5

FITTING OF BATTLE DRESS UNIFORM AND COAT, COLD WEATHER (FIELD JACKET)

5-1. MEN'S AND WOMEN'S BATTLEDRESS UNIFORMS The Battledress Uniforms, Temperate and Hot Weather (Fig. 5-1), consist of a "bush-type" coat, trousers, and a field cap. The uniform is printed in the woodland camouflage pattern. The Coat, Cold Weather (Field Jacket) is also printed in the woodland camouflage pattern. These items are worn by both male and female soldiers.

a. Design.

(1) *Coat*. The coat has four bellow type patch pockets with flaps (one on both the lower left and right fronts and one on the left and right breast), a concealed front button closure, a straight cut bottom, elbow patches and long sleeves with cuffs.

(2) *Trousers*. The trousers have a button front fly, two waist adjustment straps, right and left hip pockets with flaps, two side hanging pockets, right and left cargo pockets with flaps, seat and knee patches, and leg hem drawcords. The Hot Weather BDU has an insect protective front fly underlay flap.

(3) *Cap*. The temperate cap is visor style with a circular crown and retractable earlaps. The hot weather cap has added air vents and does not have earlaps.

(4) *Coat, Cold Weather (Field Jacket)*. The coat is a lined, hip-length design, having a bi-swing back, convertible stand-up collar with adjustable tab closure, four buttonholes and horizontal slide fastener closure on undercollar (exit for hood), attached hood (concealed between body layers) with drawcord adjustment, two-piece set-in sleeves, adjustment tab cuff closure and hand shield extension, shoulder loops with button closure, slide fastener fly front closure with snap fasteners, two bellows type breast pockets and two lower inside hanging pockets with snap fastener flap closures, waist and hem drawcords, and inside buttons for attaching of insulating liner.

b. Material.

(1) *Coat and Trousers*

(a) The Temperate Coat and Trousers are made of 50% nylon and 50% cotton twill cloth, printed in the woodland camouflage pattern.

(b) The Hot Weather Coat and Trousers are made of 50% nylon and 50% cotton wind-resistant poplin, printed in the woodland camouflage pattern.

(2) *Cap* The temperate cap is made of a cotton warp, nylon filling, water-repellent, oxford cloth, printed in the woodland camouflage pattern. The lining of the earlaps are wool and nylon flannel olive green shade 108. The hot weather cap is made of 50% nylon and 50% cotton wind-resistant poplin, printed in woodland camouflage pattern.

(3) *Coat, Cold Weather (Field Jacket)*. The coat is made of nylon and cotton sateen, wind-resistant and water-repellent fabric. The material for the lining of the coat and interlining the fronts is a wind-resistant, water-repellent cotton oxford cloth, OG-107.

TM 10-227

c. Sizing System.

(1) *Coat.* The coat is available in 22 sizes; extra-small through extra-large in extra-extra-short through extra-long lengths.

(2) *Trousers* The trousers are available in 21 sizes; extra-small through extra-large in extra-short through extra-long lengths.

(3) *Cap* The cap is available in 14 sizes with 1/8-inch increments from sizes 6 3/8 through 8. The circumference of the cap is graded in 3/8" increments.

(4) *Coat, Cold Weather (Field Jacket).* The cold weather coat is available in 18 sizes; extra-small through extra-large in extra-short through long lengths.

d. General Fitting Procedures. Although the cotton undershirt and underwear are normally worn under the Battledress Uniform, the winter underwear may also be worn with either the Hot Weather or Temperate Uniform.

(1) *Trousers*

(a) Subgarments. Underwear and cushion sole socks are required for fitting the battledress trousers.

(b) Measurement. The waist and inseam length measurements are needed for selection of the proper size and try-on garment.

(c) Try-On. Using the individual's waist and inseam measurements, refer to the size prediction table 5-1 for the size of the initial try-on garment. Make sure the bottom of the waistband is positioned plus or minus 1/2-inch from the hipbone. (Up to 3 inches is allowed at the waistline, to be adjusted accordingly with the waist straps.)

(d) Alterations. If the proper length trouser is not available, select a longer pair and shorten to proper length. This is the only alteration authorized.

Table 5-1. Trousers, BDU, Size Prediction Table.

| <u>Waist (inches)</u> | <u>Inseam (inches)</u> | <u>Trouser Size</u> |
|-----------------------|------------------------|---------------------|
| Up to 27 | Up to 26 ½ | X-Small, X-Short |
| Up to 27 | 26 ½ - 29 ½ | X-Small, Short |
| Up to 27 | 29 ½ - 32 ½ | X-Small, Regular |
| Up to 27 | 32 ½ - 35 ½ | X-Small, Long |
| 27 - 31 | Up to 26 ½ | Small, X-Short |
| 27 - 31 | 26 ½ - 29 ½ | Small, Short |
| 27 - 31 | 29 ½ - 32 ½ | Small, Regular |
| 27 - 31 | 32 ½ - 35 ½ | Small, Long |
| 27 - 31 | Over 35 ½ | Small, X-Long |
| 31 - 35 | Up to 26 ½ | Medium, X-Short |
| 31 - 35 | 26 ½ - 29 ½ | Medium, Short |
| 31 - 35 | 29 ½ - 32 ½ | Medium, Regular |
| 31 - 35 | 32 ½ - 35 ½ | Medium, Long |
| 31 - 35 | Over 35 ½ | Medium, X-Long |
| 35 - 39 | 26 ½ - 29 ½ | Large, Short |
| 35 - 39 | 29 ½ - 32 ½ | Large, Regular |
| 35 - 39 | 32 ½ - 35 ½ | Large, Long |
| 35 - 39 | Over 35 ½ | Large, X-Long |
| Over 39 | 26 ½ - 29 ½ | X-Large, Short |
| Over 39 | 29 ½ - 32 ½ | X-Large, Regular |
| Over 39 | 32 ½ - 35 ½ | X-Large, Long |

(2) *Coat*

(a) Subgarments. The cotton undershirt is required for proper fit of the battledress coat.

(b) Measurements. The chest/bust size and height measurements are needed for selection of the proper size and try-on garment.

(c) Try-On. Using the individual's height and chest/bust measurements, refer to the size prediction table 5-2 for the size of the initial try-on garment. If the individual's measurements are close to the minimum or maximum indicated on the size prediction table, select two sizes for try-on.

(d) Alterations. Alteration of the coat is not authorized.

(3) *Cap*

(a) Measurements. If the cap size is not known, measure around the largest part of the head, across the forehead and over the temples parallel to the floor.

(b) Try-On. Using the individual's head measurements and refer to the size prediction table 5-3 for the proper size cap.

(c) Alterations. Alteration of the Cap is not authorized.

Table 5-2. Coat, BDU, Size Prediction Table.

| <u>Chest/Bust (Inches)</u> | <u>Height (Inches)</u> | <u>Coat Size</u> |
|----------------------------|------------------------|------------------|
| up to 33 | 59 - 63 | X-Small, X-Short |
| up to 33 | 63 - 67 | X-Small, Short |
| up to 33 | 67 - 71 | X-Small, Regular |
| 33 - 37 | Up to 59 | Small, XX-Short |
| 33 - 37 | 59 - 63 | Small, X-Short |
| 33 - 37 | 63 - 67 | Small, Short |
| 33 - 37 | 67 - 71 | Small, Regular |
| 33 - 37 | 71 - 75 | Small, Long |
| 33 - 37 | Above 75 | Small, X-Long |
| 37 - 41 | Up to 59 | Medium, XX-Short |
| 37 - 41 | 59 - 63 | Medium, X-Short |
| 37 - 41 | 63 - 67 | Medium, Short |
| 37 - 41 | 67 - 71 | Medium, Regular |
| 37 - 41 | 71 - 75 | Medium, Long |
| 37 - 41 | Above 75 | Medium, X-Long |
| 41 - 45 | 59 - 63 | Large, X-Short |
| 41 - 45 | 63 - 67 | Large, Short |
| 41 - 45 | 67 - 71 | Large, Regular |
| 41 - 45 | 71 - 75 | Large, Long |
| 41 - 45 | Above 75 | Large, X-Long |
| Above 45 | 67 - 71 | X-Large, Regular |
| Above 45 | 71 - 75 | X-Large, Long |

Table 5-3. Cap, BDU, Size Prediction Table.

| <u>Size</u> | <u>Head Measurement</u> |
|-------------|-------------------------|
| 6 3/8 | 20 1/8 |
| 6 1/2 | 20 1/2 |
| 6 5/8 | 20 7/8 |
| 6 3/4 | 21 1/4 |
| 6 7/8 | 21 5/8 |
| 7 | 22 |
| 7 1/8 | 22 3/8 |
| 7 1/4 | 22 3/4 |
| 7 3/8 | 23 1/8 |
| 7 1/2 | 23 1/2 |
| 7 5/8 | 23 7/8 |
| 7 3/4 | 24 1/4 |
| 7 7/8 | 24 5/8 |
| 8 | 25 |

A plus or minus tolerance of 1/4 inch is allowed for each head measurement.

(4) *Coat, Cold Weather (Field Jacket).*

(a)Subgarments. The BDU Coat is required for sizing the cold weather coat.

(b)Measurements. The Chest/bust and height measurements are needed for selection of the proper size and try-on garment.

(c)Try-On. Using the individual's chest/bust and height measurements, refer to the size prediction table 5-4 for the size of the initial try-on garment. If the individual's measurements are close to the minimum or maximum indicated on the size prediction chart, select two sizes for try-on.

(d)Alterations. Alteration of the cold weather coat is not authorized.

Table 5-4. Coat, Cold Weather (Field Jacket), Prediction Table.

| <u>Chest (inches)</u> | <u>Bust (inches)</u> | <u>Height (inches)</u> | <u>Coat Size</u> |
|-----------------------|----------------------|------------------------|------------------|
| Up to 33 | Up to 36 | Up to 63 | X-Small, X-Short |
| Up to 33 | Up to 36 | 63 - 67 | X-Small, Short |
| Up to 33 | Up to 36 | 67 - 71 | X-Small, Regular |
| Up to 33 | Up to 36 | 71 and up | X-Small, Long |
| 33 - 37 | 36 - 40 | Up to 63 | Small, X-Short |
| 33 - 37 | 36 - 40 | 63 - 67 | Small, Short |
| 33 - 37 | 36 - 40 | 67 - 71 | Small, Regular |
| 33 - 37 | 36 - 40 | 71 and up | Small, Long |
| 37 - 41 | 40 - 44 | Up to 63 | Medium, X-Short |
| 37 - 41 | 40 - 44 | 63 - 67 | Medium, Short |
| 37 - 41 | 40 - 44 | 67 - 71 | Medium, Regular |
| 37 - 41 | 40 - 44 | 71 and up | Medium, Long |
| 41 - 45 | -- | 63 - 67 | Large, Short |
| 41 - 45 | -- | 67 - 71 | Large, Regular |
| 41 - 45 | -- | 71 and up | Large, Long |
| 45 and up | -- | 63 - 67 | X-Large, Short |
| 45 and up | -- | 67 - 71 | X-Large, Regular |
| 45 and up | -- | 71 and up | X-Large, Long |

e. Final Check for Concept of Fit.

(1) *Trousers* When fitting the trousers, an exact fit is not required. Fit the trousers with the bottom of the waistband resting at the top of the hipbone and check the following points.

(a)Waist. When buttoned and waist straps adjusted, the trousers must fit easily at the waist.

(b)Hips and Seat. The trousers must fit loosely enough at the hips and seat to allow squatting and bending (Fig. 5-1).

(c)Crotch. The crotch of the trousers should not bind.

TM 10-227

(d)Length. The legs of the trousers must be long enough to allow blousing over combat boots.

(2) *Coat* Completely button the coat and check the following points.

(a)Chest/Bust and Shoulders. The coat, when fully buttoned, must fit easily over the chest/bust and shoulders, allowing free use of arms without discomfort.

(b)Hips. The coat must hang freely from the shoulders without tightness around the waist or hips. Coat fronts should be smooth and even at the bottom edges. The bottom edges in the front of the coat will protrude if the coat is too snug at the waist and hips.

(c)Length. The bottom edge of the coat must extend to the crotch. The bottom edge of the coat should fall near the top of the trouser cargo pocket flap.

(3) *Cap*. The cap should fit snugly and level over the head, with the visor straight across the fore-head. The bill of the cap should not block the individual's vision.

(4) *Coat, Cold Weather (Field Jacket)*. Check the following points while the individual is wearing the coat, completely closed, and worn over the BDU coat with arms by his/her side.

(a)Chest/Bust and Shoulders. The coat, when fully fastened, must fit easily over the chest/bust and shoulders, allowing free use of the arms without discomfort.

(b)Hips. The coat must hang freely from the shoulders without tightness around the waist or hips (Fig. 5-2). Coat fronts should be smooth and even at the bottom edges. The bottom edges in the front of the coat will protrude if the coat is too snug at the waist and hips.

(c)Length. The bottom edge of the coat must fall below and completely cover the BDU Coat underneath by a least one inch in length (Fig. 5-2).

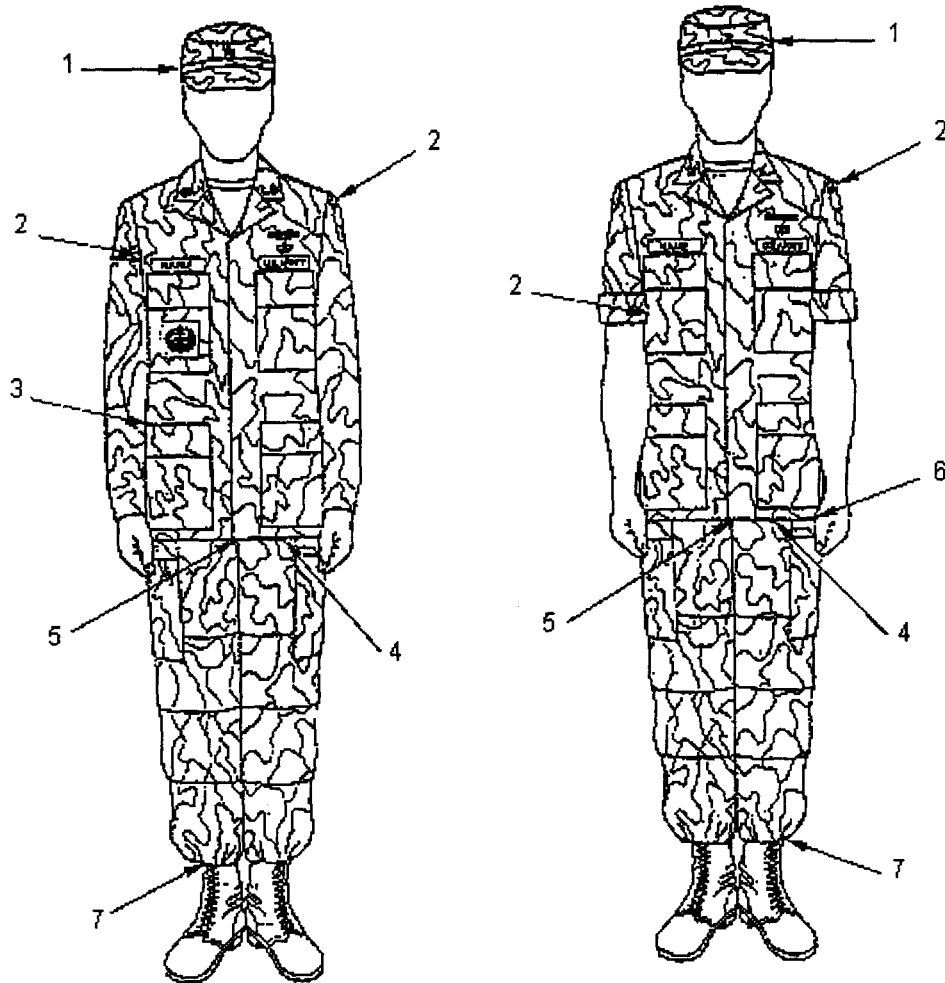

1. The cap should fit snugly and level over the head, with the visor straight across the forehead.
2. Coat should fit easily over chest/bust and shoulders, allowing free use of arms without discomfort.
3. Coat must hang freely from the shoulders without tightness around the waist or hips.
4. Bottom edge of the coat must extend to the crotch area near the top of the trousers cargo pocket flap.

5. The crotch of the trousers should not bind.
6. Trousers must fit loosely enough at hips and seat to allow squatting and bending.
7. The legs of the trousers must be long enough to allow blousing over the combat boots.

Figure 5-1. Fit of Battledress (Hot Weather or Temperate) Uniform.

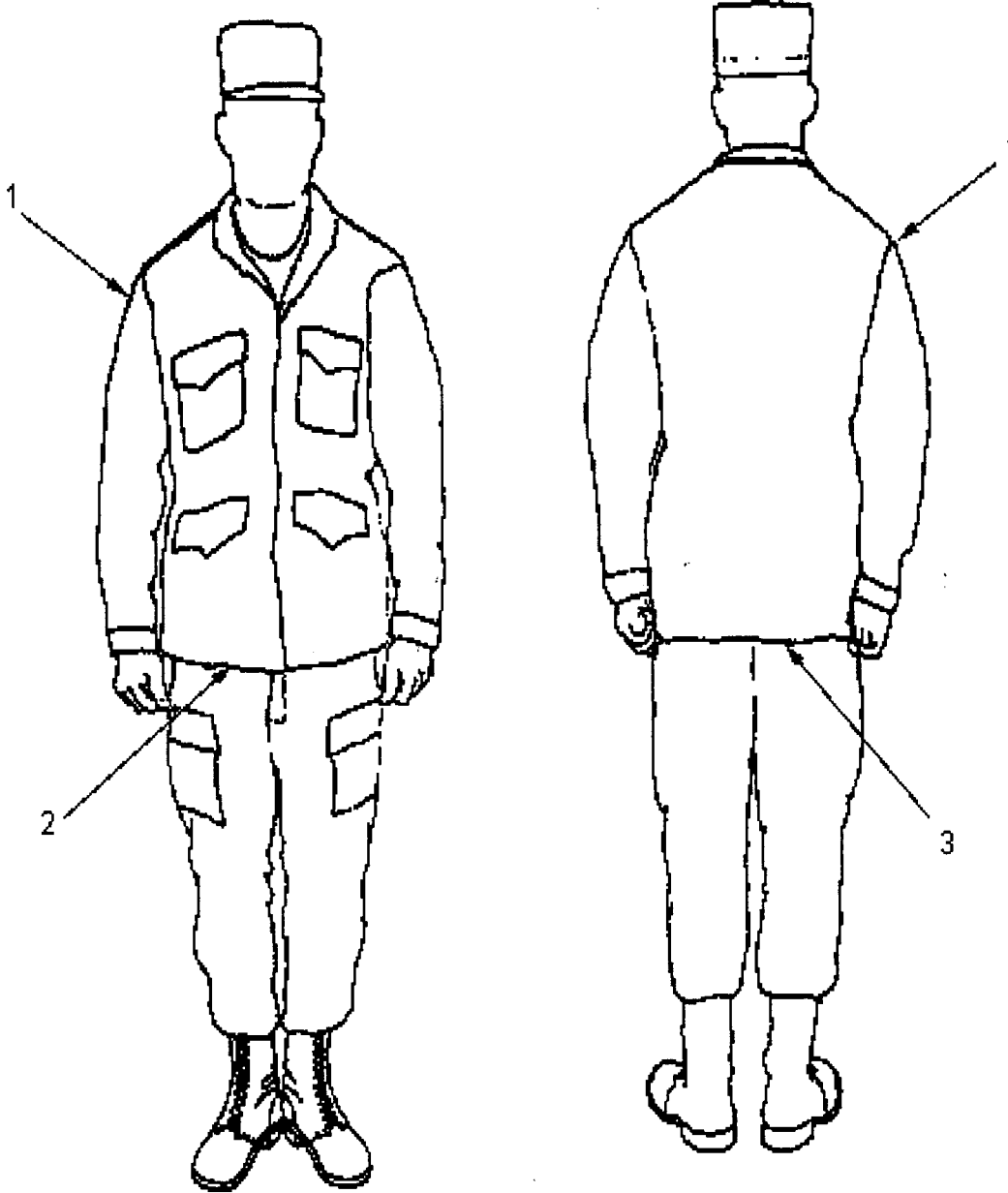

1. The coat must fit easily over the chest/bust and shoulders, allowing free use of arms without discomfort.

2. Coat fronts should be smooth and even at the bottom edges.

3. The bottom edge of the coat must fall below and completely cover the BDU Coat underneath by at least 1 inch.

Figure 5-2. Fit of Coat, Cold Weather (Field Jacket).

CHAPTER 6

FITTING OF FOOTWEAR ITEMS

6-1. GENERAL PRINCIPLES. Proper fitting of military footwear depends on the effectiveness and knowledge of the fitter. The following principles are provided as a basis for proper fitting methods and techniques.

a. Foot Construction. The foot is so constructed that each of its parts contributes directly to the supporting and transportation of the body weight. Structure, shape, and size of feet vary considerably with some feet long and narrow, and others short and wide. An individual's two feet are also seldom exactly alike. Despite their normal differences, most individuals can be correctly and comfortably fitted with standard military footwear.

b. Concept of Fit. The basic goals of proper fitting are to ensure maximum comfort and prevent foot injury. Properly fitted footwear will hold the foot securely from the lacing at the instep to the heel and have sufficient room in the front for the foot to be free from restriction (Fig. 6-1).

c. Misfitted Footwear. Improperly fitted footwear may cause many ailments, not all of them confined to the foot. The continual wearing of misfitted footwear may affect health, morale and efficiency. Fallen arches, bunions, callouses, corns, blisters, ingrown toenails, distorted toes and aching feet often result from poorly fitted footwear. Following are three types of misfitted footwear and the problems they may cause.

(1) *Short Footwear.* Short footwear prevents natural expansion of the foot. Back pressure of the forepart of the foot transmitted to the arch jams archbones out of normal position and contributes to fallen arches. Pressure forces a spreading of the toe joints, irritates the great and little toes, and contributes to ingrown toenails and the formation of bunions.

(2) *Tight Footwear.* Tight footwear presses the toes together so that they often overlap and restrict the flow of blood. Frequently, the bottom of the foot is extended over the edge of the innersole, gradually pressing a groove into the flesh. This pressure causes the flesh to become sore and painfully calloused. Corns may form between and over the toes and the feet may become weakened, distorted, and permanently injured.

(3) *Oversize Footwear.* Oversize footwear prevents normal foot function by failing to provide adequate support. As the foot spreads, it throws the weight-bearing portion of the foot out of position and abnormally expands the arch. The foot tends to ride forward and sideways, causing chafing at the heel, toes, bottom, and outside of the foot. When worn for running or long marches, oversize footwear will cause discomfort and fatigue.

6-2. MEASURING AND FITTING OF FOOTWEAR ITEMS.

a. Fitting of Socks. Check socks when the individual is standing, weight evenly distributed on both feet. Socks should fit with no apparent tightness or fullness (wool socks should be fitted slightly larger to allow for shrinkage). The Size Correlation Chart Table 6-1, is only a guide for selecting the initial try-on size. Socks should be tried on and checked for proper fit.

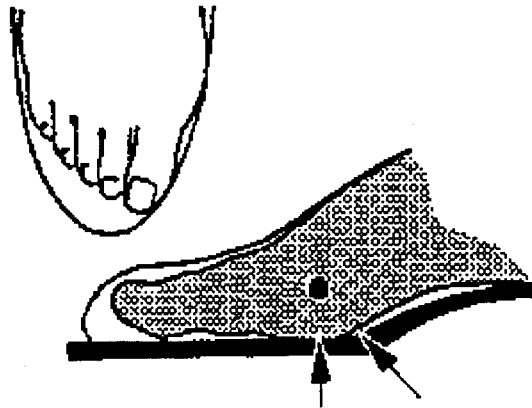

A. THIS FOOT IS IMPROPERLY FITTED

The toes are cramped and twisted. This condition stops ventilation and causes excessive perspiration which results in rotting of inner soles, linings, and upper leather. Short shoes such as these cause enlarged great-toe joints and bunions, as well as general foot discomfort. Each step strains the foot arch. Without support under its entire arch span, the foot sags down, nerve and blood vessels are pinched, thereby interfering with circulation. Foot ailments usually follow these conditions.

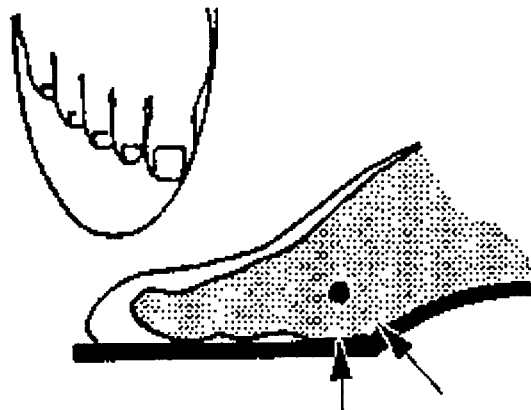

B. THIS FOOT IS PROPERLY FITTED

Arch base of shoe and ball joint of foot meet at the same point. Foot arch rests comfortably on shank of shoe, full length. Foot and shoe bend at same place—no sagging. Toes are straight. There is ample space in front of the toes—no crowding of toes, ample ventilation. These feet should be comfortable.

Figure 6-1. Proper Fitting of Footwear.

Table 6-1. Size Correlation for Socks

| <u>Shoes/Boot Size</u> | <u>Sock Size</u> |
|------------------------|------------------|
| 3 through 8-1/2 | X-Small |
| 9 through 10 | Small |
| 10-1/2 through 11-1/2 | Medium |
| 12 through 13-1/2 | Large |
| 14 and over | X-Large |

b. Foot Measuring Device.

(1) *Use.* The foot measuring device (Fig. 6-2), NSN 8335-00-421-2147, is used to measure the individual's feet for the initial try-on size. There are two other foot measuring devices that can be used to measure men's or women's feet for the initial try-on size, NSN 8335-01-463-7079 for men and NSN 8335-01-463-8139 for women. The devices measure the "heel to ball" length and the "ball" width. Even though the devices have proven to be 75% accurate, the actual size to be issued must be determined after the footwear has been tried on and checked for proper fit.

(2) *Operation.* To ensure an accurate measurement, make sure the individual is wearing properly fitted socks; black or olive green wool socks for combat boots and nylon black socks for low quarter shoes. Women's dress oxfords should be fitted while wearing nylons. There should be no apparent tightness or excessive fullness of the material. Following are the operation procedures for the foot measuring device.

(a) Seat the individual being fitted so the foot measuring device is located directly below the knees. In this position, the legs and feet are relaxed and can be easily placed on the device.

(b) Place hands over the instep and position both feet on the device making sure the feet are fitted snugly against the heel stop.

(c) Have the individual stand and remove hands from instep.

(d) Adjust the "heel to ball" measurement bar until it fits properly against the ball joint of the great toe. Hold in position and slide the ball width bar until it gently presses against the outer ball of the foot.

(e) First read the "heel to ball" length measurement, then find the same length number on the ball width bar and determine the appropriate width. For example: if the "heel to ball" length measures size 8, and the number 8 on the ball width bar is in the "R" width block, the try-on size would be 8R. If the number on the ball width bar is near the dividing line of two widths, select the larger width for the try-on size.

(f) Repeat on opposite foot.

c. Selection for Initial Try-On Size.

(1) *Determining Length Size.* Measure each foot separately and select initial try-on size by comparing the measured length of each foot. Select the initial try-on size as follows:

(a) If both feet measure the same length size, select that size for the initial try-on. For example, if both feet measure size 8, select size 8 for initial try-on.

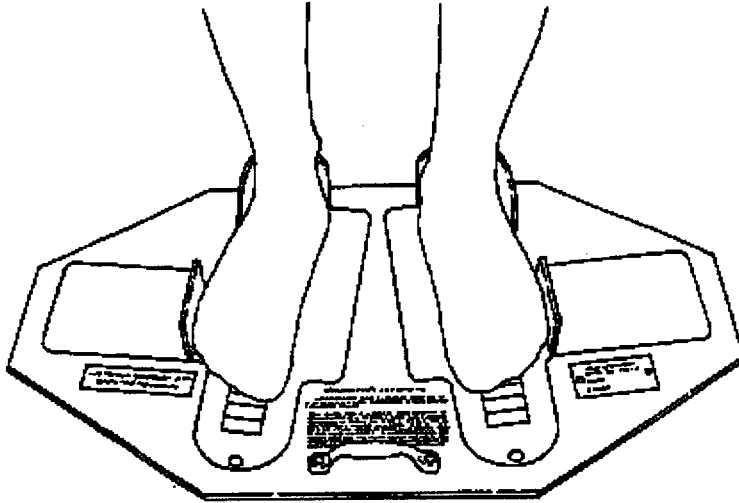

Figure 6-2. Operating Procedures for Foot Measuring Device.

(b) If one foot measures one-half size longer than the other, select the longer size for initial try-on.

(c) If one foot measures a full size longer, select the size half-way between the two sizes that were measured. For example, if one foot measures 8 1/2 and the other 7 1/2, select size 8 for the initial try-on.

(d) When an individual cannot be properly fitted with one tariff size, try-on two different sizes. If the proper fit is achieved with two different sizes, there is no need for special measurement footwear. The individual will only be charged the single pair price and the remaining unused footwear disposed of in accordance with AR 700-84.

(2) *Determine Width Size.* Measure each foot separately compare the measured width of each foot as follows:

(a) If both feet measure the same width, select that width for initial try-on. For example, if both feet measure regular (R) width, select the regular width for initial try-on.

(b) If one foot measures a full width wider than the other the wider measurement is used to select the try-on size.

(c) If one foot measures two widths wider than the other, select the width half-way between the two measurements. For example, if one foot measures regular (R) and the other measures extra narrow (XN), select narrow (N) for initial try-on.

(d) If the foot measures more than half-way between two widths, select the larger width for initial try-on. If the foot measures less than half-way, select the smaller width.

(e) When an individual cannot be properly fitted with one width of a specific footwear item, try on two different widths. If the proper width is achieved, special measurement footwear is not required. The individual will be charged the single pair price and the remaining unused footwear disposed of in accordance with AR 700-84.

d. Fitting of Footwear. During the initial fitting, the fitter should take as much time as necessary; with each individual to ensure a correct fit. Misfits are not only expensive, but continued wear may result in physical injury to the wearer. To minimize the number of misfits, the fitter should first make sure the individual is wearing properly fitted socks and the shoes/boots are completely laced and tied (boots must be laced at least through the bottom five eyelets). With the individual standing, weight evenly distributed on both feet, the fitter must make the following checks.

(1) *Arch Fit*. To check arch fit, position the right hand over the instep of the individual's right shoe/boot (Fig. 6-3). Press the fingers firmly against the inner arch close to the sole, making sure the leather fits snug, but not tight, against the under arch. The arch area of the shoe/boot should be free from wrinkles or excessive fullness (Fig. 6-4). Check the left shoe/boot in the same manner, using the left hand.

(2) *Ball-Joint Position*. Locate the ball-joint position with the thumb of each hand (Fig. 6-5). When correctly positioned, the ball-joint will be opposite the widest part of the shoe/boot, and the vamp will fall directly across the toe joint. The ball-joint position should also be checked while the individual is in the "full knee bend" position. With the individual in this position, heels off the floor, the ball-joint should be in line with the break in the shoe/boot (Fig. 6-6).

(3) *Width*. To check the shoe width, place a thumb on each side of the shoe near the ball-joint. Press thumbs firmly, working each thumb towards the center of the shoe/boot until they almost meet (Fig. 6-7). The foot should fill the shoe/boot without tightness; however, excessive fullness should be avoided. It is better to allow a slight fullness of the leather at this point, rather than the shoe/boot fitting too snugly.

(4) *Length*. To check toe clearance, depress the front of the shoe/boot with the thumb: there should be at least 1/2-inch of clearance between the longest toe and the end of the shoe/boot (Fig. 6-7). The foot should fill the shoe/boot without tightness; however, excessive fullness should be avoided. It is better to allow a slight fullness of the leather at this point, rather than the shoe/boot fitting too snugly.

6-3. SHOE FITTING FACILITIES.

a. General Requirements. The fitting area should be equipped with a shoe fitting platform, foot measuring devices, and an adequate number of chairs, benches and tables. The shoe fitting platform should be designed to conform to the physical arrangement and available space at the facility, and should be large enough to accommodate the number of individuals normally processed daily.

b. Shoe-Fitting Platform. A shoe fitting platform (Fig 6-9) 16 ft. long, 3 ft. wide, and 34 in. high is recommended. The platform should be equipped with a 12 ft. long bench, 14 in. wide and 18 in. high, with a 9 ft. long kickboard.

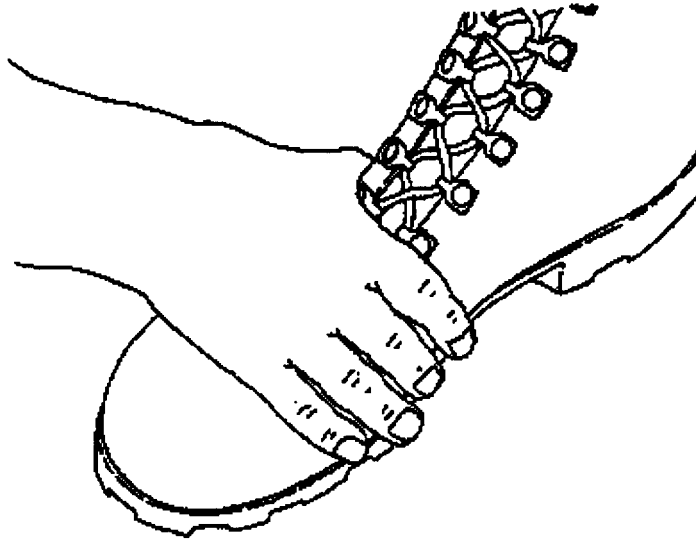
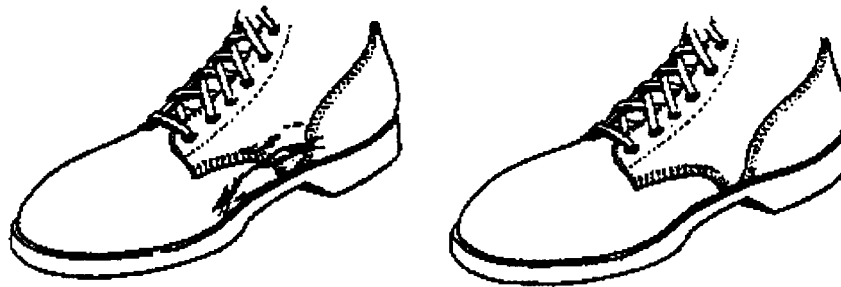

Figure 6-3. Measuring Arch Fit.



A. IMPROPER FIT

B. PROPER FIT

WRINKLES AND POCKETS IN ARCH

NO WRINKLES OR POCKETS IN ARCH

Figure 6-4. Proper and Improper Arch Fit.

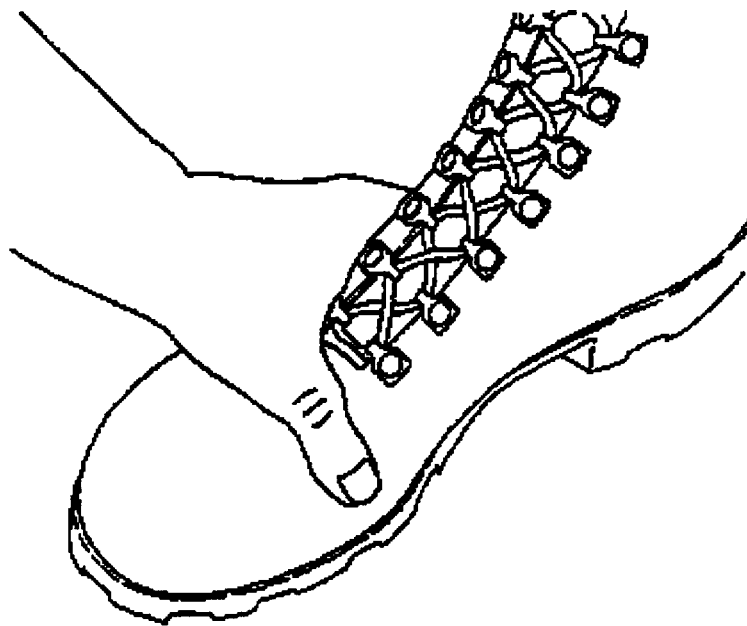

Figure 6-5. Locating Ball Joint Position.

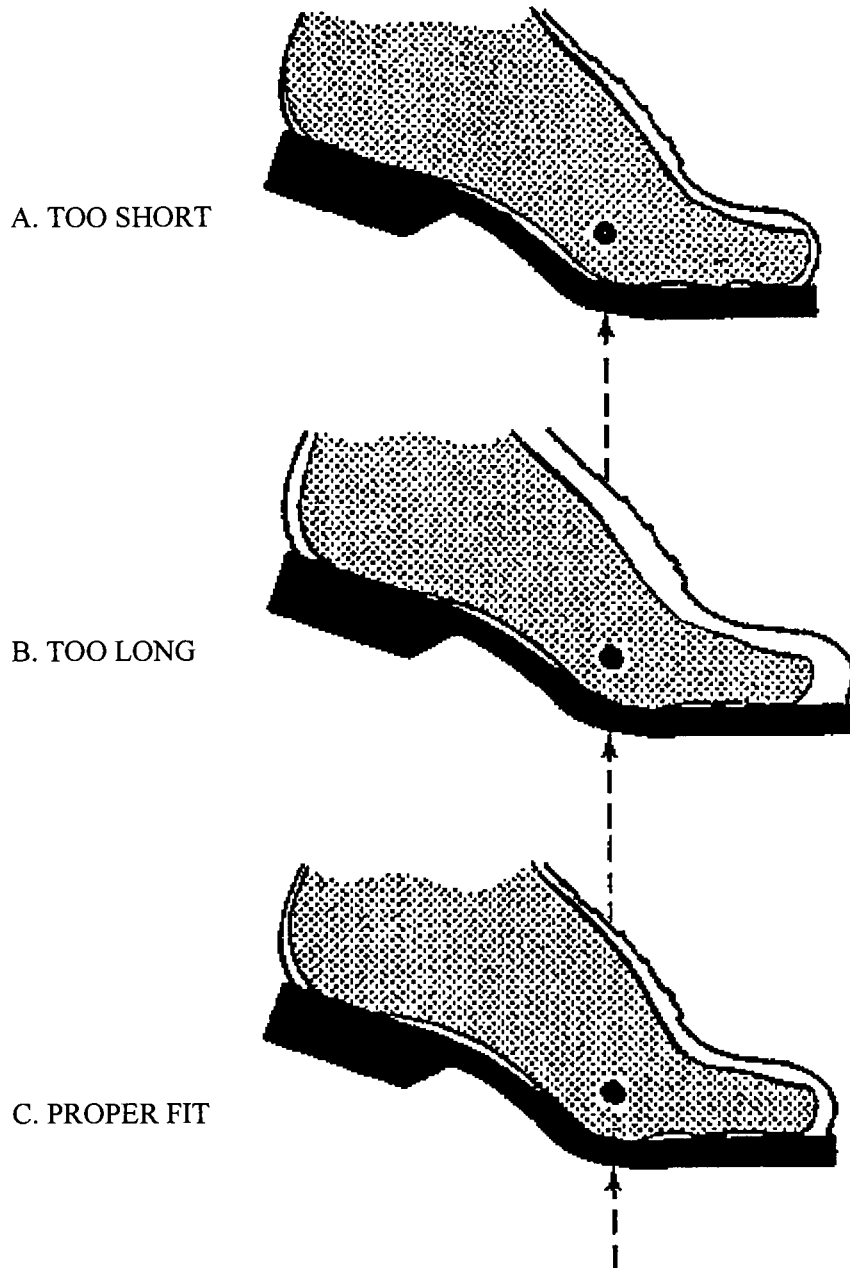
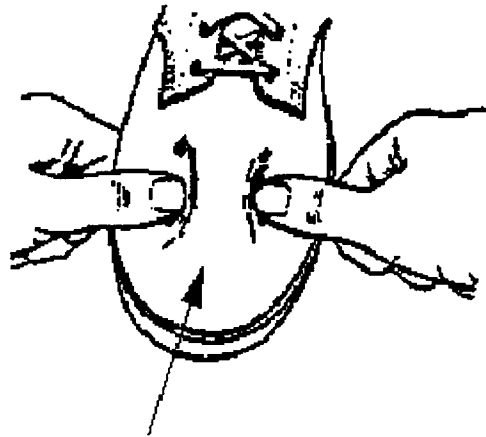
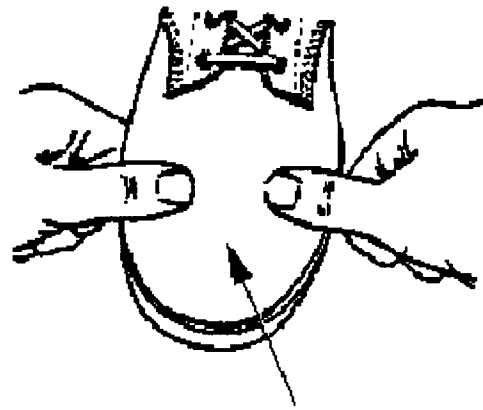

Figure 6-6. Proper and Improper Ball Joint.



EXCESS LEATHER

A. IMPROPER FIT



NO EXCESS LEATHER

B. PROPER FIT

Figure 6-7. Proper and Improper Shoe/Boot Width.



A. TOO SHORT



B. TOO LONG

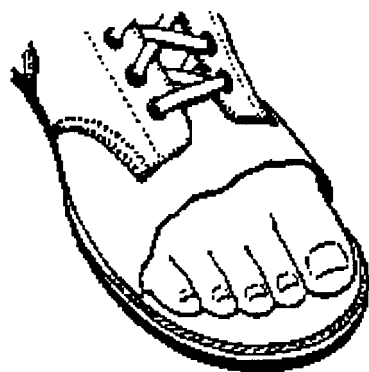

C. PROPER FIT

Figure 6-8. Proper and Improper Foot Clearance in Shoe.

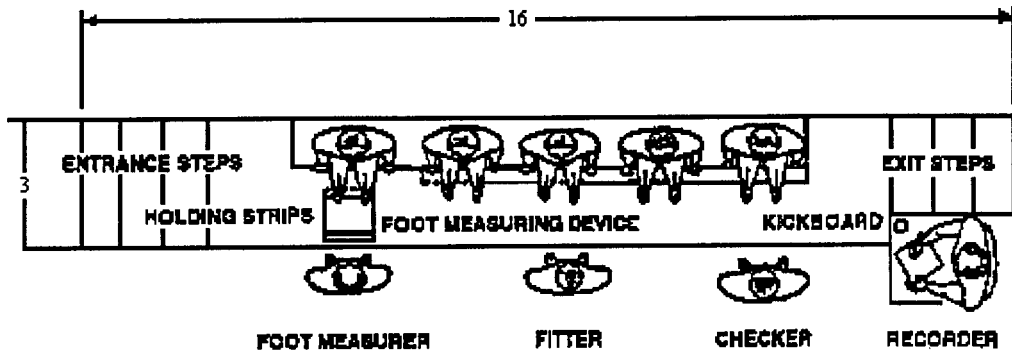

Figure 6-9. Shoe Fitting Platform.

THIS PAGE INTENTIONALLY LEFT BLANK

APPENDIX A

REFERENCES

A.1 GENERAL. This appendix lists all forms, field manuals, technical manuals and miscellaneous publications referenced in this manual.

A.2 FORMS.

Recommended Changes to Publications and Blank Forms DA Form 2028

A.3 FIELD MANUALS.

General Fabric Repair FM 10-16
 First Aid for Soldiers FM 21-11
 Foot Marches FM 21-18

A.4 ARMY REGULATIONS.

Special Measurement Clothing and Footwear, Orthopedic Footwear AR 32-4
 Medical, Dental and Vetrinary Care AR 40-3
 Wear and Appearance of Army Uniforms and Insignia AR 670-1
 Issue and Sale of Personnel Clothing AR 700-84

A.5 TECHNICAL MANUALS.

General Repair Procedures for Clothing TM 10-8400-201-23
 General Repair Procedures for Individual Equipment TM 10-8400-203-23

A.6 MISCELLANEOUS.

Size Tariff for Clothing, Equipage and Footwear SB 10-523
 Clothing and Individual Equipment CTA 50-900
 Standardization Agreement (Interchangeability of
 Combat Clothing Sizes) CTA 50-900

THIS PAGE INTENTIONALLY LEFT BLANK

APPENDIX B

LIST OF APPLICABLE DATA FOR CLOTHING AND FOOTWEAR ITEMS.

The following table lists NSN's, LIN, Military Specifications and Nomenclature for Men's Clothing, Women's Clothing, and Footwear.

| | | | |
|---|---------|-------------|-----------------------|
| | | | 8440-00-573-1765 |
| | | | 8440-01-204-2610 |
| Cap, Garrison, Men's, Poly/Wool, AG 489 | D01489 | MIL-C-43419 | 8405-01-334-1493/1505 |
| Coat, All-Weather, Men's, W/Removable Liner | R09708 | A-A-55260 | 8405-01-308-8673/8714 |
| | | | 8405-01-400-6106/6107 |
| | | | 8405-01-400-6117/6118 |
| Coat, Men's, Poly/Wool Serge, AG 489 | E4426 1 | MUX-442 11 | 8405-01-330-7383 |
| | | | 8405-01-330-7388 |
| | | | 8405-01-330-7391/7393 |
| | | | 8405-01-330-7395/7398 |
| | | | 8405-01-330-7400/7419 |
| | | | 8405-01-330-7421/7423 |
| | | | 8405-01-330-7426/7438 |
| | | | 8405-01-330-7440 |
| | | | 8405-01-330-7443/7444 |
| | | | &405-01-399-3920/3921 |
| Drawers, Men's, Brief, Brown 436 | G48939 | A-A-50003 | 8420-01-112-1957/1965 |
| Neckties, Men's | M97044 | A-A-55119 | 8440-01-171-7571 |
| Shirts, Man's, Long Sleeve, AG 415 | T03070 | A-A-52112 | 8405-01-311-9691/9719 |
| | | | 8405-01-311-3780/3783 |
| | | | 8405-01-395-2604/2605 |
| | | | 8405-01-397-1979 |
| | | | 8405-01-397-0993/0994 |
| | | | 8405-01-397-0996 |
| Shirts, Man's, Short Sleeve, AG-415 | TBD | A-A-52112 | 8405-01-374-8887/8895 |
| | | | 8405-01-395-2602 |
| Socks, Wool/Nylon, Black Cushion Sole | T93335 | MIL-S-48 | 8440-01-053-6769 |
| | | | 8440-00-543-7777/7779 |
| | | | 8440-01-343-8095 |

MEN'S CLOTHING (continued)

| <u>Nomenclature</u> | <u>LIN</u> | <u>MILSpec/CID</u> | <u>NSN</u> |
|---|------------|--------------------|--|
| Socks, Cotton/Nylon, Black | T92171 | MIL-S-12549 | 8440-00-543-7773/7775 8440-00-883-8672 |
| Trousers, Men's, Poly/Wool, AG 489 | X36906 | MIL-T-43957 | 8405-01-331-9967/9999 8405-01-342-0000/0020 8405-01-399-3065 |
| Undershirt, Men's, Cotton, White, Quarter Length Sleeve | X86702 | A-A-50013 | 8420-00-543-6643/6650 |

WOMEN'S ITEMS

| | | | |
|---|--------|-------------|---|
| Belt, Cotton Web, Black, 1" | | MIL-B-833 | 8445-01-075-0015 |
| Belt, Trousers, Cotton Web, Black | B60252 | MIL-B-833 | 8440-00-573-1666 8440-00-573-1765 8440-01-204-2610 |
| Buckle, Brass, Yellow, 1-1/2" | | MIL-B-1963 | 8315-01-075-1818 |
| Cap, Garrison, Women's, Poly/Wool AG 489 | B62824 | MIL-C-44130 | 8410-01-333-9700/9710 |
| Coat, All-Weather, Women's, Black | R09914 | MIL-C-29381 | 8410-01-308-8649/8672 8410-01-400-6129 |
| Coat, Women's, Poly/Wool Serge, AG 489 | E45357 | MIL-C-44379 | 8410-01-341-9897/9958 8410-01-399-3909 8410-01-399-3913 8410-01-399-3917 |
| Necktab, Women's, Black | | MIL-N-29367 | 8445-01-396-8105 |
| Shirt, Women's, Tuck-In, Long Sleeve AG 415 | | A-A-55283 | 8410-01-415-1571/1585 8410-01-415-1589 8410-01-415-1592 8410-01-415-1594 8410-01-415-2905 8410-01-415-2907/2908 8410-01-415-2910 8410-01-415-2912/2914 8410-01-415-7023 8410-01-415-7027 8410-01-415-8425 8410-01-415-8427 8410-01-443-8989 8410-01-443-9016 8410-01-443-9022 8410-01-443-9027 8410-01-443-9029 8410-01-443-9084 8410-01-443-9088 8410-01-443-9110 |

WOMEN'S ITEMS (Continued)

| <u>Nomenclature</u> | <u>LIN</u> | <u>MIL Spec/CID</u> | <u>NSN</u> |
|--|------------|---------------------|--|
| Shirt, Women's, Tuck-In, Long Sleeve AG 415 (Continued) | | A-A-55283 | 8410-01-443-9117 |
| | | | 8410-01-443-9122 |
| | | | 8410-01-443-9380 |
| | | | 8410-01-443-9384 |
| | | | 8410-01-443-9389 |
| | | | 8410-01-443-9394 |
| | | | 8410-01-443-9405 |
| | | | 8410-01-443-9411 |
| | | | 8410-01-443-9425 |
| | | | 8410-01-443-9499 |
| Shirt, Women's, Tuck-In, Short Sleeve AG 415 | | A-A-55283 | 8410-01-414-6979/6981 |
| | | | 8410-01-414-7023 |
| | | | 8410-01-414-7105 |
| | | | 8410-01-414-7113 |
| | | | 8410-01-414-7116 |
| | | | 8410-01-414-7118 |
| | | | 8410-01-414-7120 |
| | | | 8410-01-414-7186 |
| | | | 8410-01-414-7232/17233 |
| | | | Skirt, Women's, PolyWool Serge AG 489 |
| 8410-01-399-2066/2068 | | | |
| Slacks, Women's, Poly/Wool Serge AG 489 | | A-A-55285 | 8415-01-415-2906 |
| | | | 8415-01-415-2909 |
| | | | 8415-01-415-2911 |
| | | | 8415-01-415-5138/5145 |
| | | | 8415-01-415-6989/7001 |
| | | | 8415-01-415-7007/7019 |
| | | | 8415-01-415-7021/7022 |
| | | | 8415-01-415-7024/7026 |
| | | | 8415-01-415-702817030 |
| | | | 8415-01-415-8446 |
| | | | 8415-01-415-8450 |
| | | | 8415-01-415-8453 |
| | | | 8415-01-415-8455 |
| | | | 8415-01-415-8457 |
| | | | 8415-01415-8460 |
| Socks, Wool/Nylon, Black, Cushion Sole | T93335 | ML-S-48 | 8415-01-415-8572/8573 |
| | | | 8440-01-053-6769 |
| | | | 8440-00-543-7777/7779 |
| | | | 8440-01-343-8095 |
| | | | |

WOMEN'S ITEMS (Continued)

| <u>Nomenclature</u> | <u>LIN</u> | <u>MIL Spec/CID</u> | <u>NSN</u> |
|--|------------|---------------------|-----------------------|
| Undershirt, Brown 436, Quarter Length Sleeve | X86565 | A-A-50013 | 8420-01-112-1472/1479 |

BATTLEDRESS UNIFORM ITEMS

| | | | |
|--|--------|-------------|--|
| Cap, Woodland Camouflage Pattern, Temperate | C01123 | A-A-55312 | 8415-01-084-1683/1694 8415-01-393-7813 |
| Cap, Hot Weather | | A-A-55294 | 8415-01-393-629116299 8415-01-393-7813 8415-01-393-7820 8415-01-393-7952 8415-01-431-8921/8922 |
| Coat, Woodland Camouflage Pattern, Temperate, BDU | C43302 | MIL-C-44048 | 8415-01-084-1639/1656 8415-01-134-3170/3173 |
| Coat, Woodland Camouflage Pattern, Hot Weather, BDU | C64956 | MIL-C-44048 | 8415-01-184-1318/1339 |
| Enhanced Coat, HWBDU | | MIL-C-44048 | 8415-01-390-853718557 |
| Coat, Cold Weather, Woodland Camouflage Pattern | E43851 | MIL-C-43455 | 8415-01-099-782517842 |
| Trousers, Woodland Camouflage Pattern, Temperate, BDU | T35160 | MIL-C-44047 | 8415-01-084-7825/1017 8415-01-084-17050718 8415-01-134-3193/3197 |
| Enhanced Trousers, HWBDU | | MIL-T-44047 | 8415-01-390-8939/8954 |
| Trousers, Woodland Camouflage Pattern, Hot Weather BDU | T35160 | MIL-T-44047 | 8415-01-184-1340/1360 |
| Undershirt, Brown 436, Quarter Length Sleeve | X86565 | A-A-50013 | 8420-01-112-1472/1479 |

FOOTWEAR ITEMS

| | | | |
|--------------------------------------|--------|---------------|--|
| Boots, Combat, Black | CO6749 | MIL-B-44152 | 8430-01-198-1325/1435 8430-01-221-327213293 |
| Shoes, Dress, Oxford, Men's, Black | TO6486 | MIL-S-13192 | 8430-00-559-4136/4298 |
| Shoes, Dress, Oxford, Women's, Black | TO6897 | MIL-S-2 17 11 | 8435-01-075-8152/8156 8435-01-075-8386/8388 |

By Order of the Secretary of the Army:

ERIC K. SHINSEKI
General, United States Army
Chief of Staff

Official:

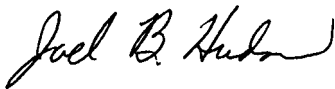

JOEL B. HUDSON
Administrative Assistant to the
Secretary of the Army
05958

DISTRIBUTION: To be distributed in accordance with Initial Distribution (IDN 250815) requirements for TM 10-227.

THIS PAGE INTENTIONALLY LEFT BLANK

These are the instructions for sending an electronic 2028

The following format must be used if submitting an electronic 2028. The subject line must be exactly the same and all fields must be included; however only the following fields are mandatory: 1, 3, 4, 5, 6, 7, 8, 9, 10, 13, 15, 16, 17, and 27.

From: "Whomever" <whomever@avma27.army.mil>

To: amsscsr@natick-amed02.army.mil

Subject: DA Form 2028

1. **From:** Joe Smith
2. **Unit:** home
3. **Address:** 4300 Park
4. **City:** Hometown
5. **St:** MO
6. **Zip:** 77777
7. **Date Sent:** 19-OCT-93
8. **Pub no:** 55-2840-229-23
9. **Pub Title:** TM
10. **Publication Date:** 04-JUL-85
11. **Change Number:** 7
12. **Submitter Rank:** MSG
13. **Submitter FName:** Joe
14. **Submitter MName:** T
15. **Submitter LName:** Smith
16. **Submitter Phone:** 123-123-1234
17. **Problem: 1**
18. **Page:** 2
19. **Paragraph:** 3
20. **Line:** 4
21. **NSN:** 5
22. **Reference:** 6
23. **Figure:** 7
24. **Table:** 8
25. **Item:** 9
26. **Total:** 123
27. **Text:**

This is the text for the problem below line 27.

THIS PAGE INTENTIONALLY LEFT BLANK

RECOMMENDED CHANGES TO EQUIPMENT TECHNICAL PUBLICATIONS



THEN . . . JOT DOWN THE DOPE ABOUT IT ON THIS FORM, CAREFULLY TEAR IT OUT, FOLD IT AND DROP IT IN THE MAIL!

SOMETHING WRONG WITH THIS PUBLICATION?

FROM: (PRINT YOUR UNIT'S COMPLETE ADDRESS)

*PFC John DOE
CO A 3rd Engineer Bn
Ft. Leonardwood, MO 63108*

DATE SENT

22 August 1992

PUBLICATION NUMBER

TM 1-1520-250-10

PUBLICATION DATE

15 June 1992

PUBLICATION TITLE

Operator's manual MH60K Helicopter

BE EXACT PIN-POINT WHERE IT IS

IN THIS SPACE, TELL WHAT IS WRONG AND WHAT SHOULD BE DONE ABOUT IT:

| PAGE NO | PARA-GRAPH | FIGURE NO | TABLE NO |
|---------|------------|-----------|----------|
| 6 | 2-1 a | | |
| B1 | | 4-3 | |

In line 6 of paragraph 2-1a the manual states the engine has 6 cylinders. The engine on my set only has 4 cylinders. Change the manual to show 4 cylinders.

Callout 16 on figure 4-3 is pointed at a bolt. In key to figure 4-3, item 16 is calle a shim. Please correct one or the other

FILL IN YOUR
UNITS ADDRESS



FOLD BACK



DEPARTMENT OF THE ARMY



OFFICIAL BUSINESS

COMMANDER
U.S. ARMY SOLDIER SYSTEMS COMMAND
ATTN: AMSSB-RIM-E
KANSAS STREET
NATICK, MA 91760-5000

RECOMMENDED CHANGES TO EQUIPMENT TECHNICAL PUBLICATIONS



SOMETHING WRONG WITH THIS PUBLICATION?

THEN . . . JOT DOWN THE DOPE ABOUT IT ON THIS FORM, CAREFULLY TEAR IT OUT, FOLD IT AND DROP IT IN THE MAIL!

FROM: (PRINT YOUR UNIT'S COMPLETE ADDRESS)

DATE SENT

PUBLICATION NUMBER

TM 10-227

PUBLICATION DATE

30 December 2000

PUBLICATION TITLE

Fitting of Army Uniforms and Footwear

BE EXACT PIN-POINT WHERE IT IS IN THIS SPACE, TELL WHAT IS WRONG AND WHAT SHOULD BE DONE ABOUT IT:

PAGE
NO

PARA-
GRAPH

FIGURE
NO

TABLE
NO

FILL IN YOUR
UNITS ADDRESS



FOLD BACK



DEPARTMENT OF THE ARMY



OFFICIAL BUSINESS

COMMANDER
U.S. ARMY SOLDIER SYSTEMS COMMAND
ATTN: AMSSB-RIM-E
KANSAS STREET
NATICK, MA 91760-5000

RECOMMENDED CHANGES TO EQUIPMENT TECHNICAL PUBLICATIONS



SOMETHING WRONG WITH THIS PUBLICATION?

THEN . . . JOT DOWN THE DOPE ABOUT IT ON THIS FORM, CAREFULLY TEAR IT OUT, FOLD IT AND DROP IT IN THE MAIL!

FROM: (PRINT YOUR UNIT'S COMPLETE ADDRESS)

DATE SENT

PUBLICATION NUMBER

TM 10-227

PUBLICATION DATE

30 December 2000

PUBLICATION TITLE

Fitting of Army Uniforms and Footwear

BE EXACT PIN-POINT WHERE IT IS IN THIS SPACE, TELL WHAT IS WRONG AND WHAT SHOULD BE DONE ABOUT IT:

| PAGE NO | PARA- GRAPH | FIGURE NO | TABLE NO |
|------------|----------------|--------------|-------------|
| | | | |

FILL IN YOUR
UNITS ADDRESS



FOLD BACK



DEPARTMENT OF THE ARMY



OFFICIAL BUSINESS

COMMANDER
U.S. ARMY SOLDIER SYSTEMS COMMAND
ATTN: AMSSB-RIM-E
KANSAS STREET
NATICK, MA 91760-5000

The Metric System and Equivalents

Linear Measure

1 centimeter = 10 millimeters = .39 inch
 1 decimeter = 10 centimeters = 3.94 inches
 1 meter = 10 decimeters = 39.37 inches
 1 dekameter = 10 meters = 32.8 feet
 1 hectometer = 10 dekameters = 328.08 feet
 1 kilometer = 10 hectometers = 3,280.8 feet

Weights

1 centigram = 10 milligrams = .15 grain
 1 decigram = 10 centigrams = 1.54 grains
 1 gram = 10 decigrams = .035 ounce
 1 dekagram = 10 grams = .35 ounce
 1 hectogram = 10 dekagrams = 3.52 ounces
 1 kilogram = 10 hectograms = 2.2 pounds
 1 quintal = 100 kilograms = 220.46 pounds
 1 metric ton = 10 quintals = 1.1 short tons

Liquid Measure

1 centiliter = 10 milliliters = .34 fl. ounce
 1 deciliter = 10 centiliters = 3.38 fl. ounces
 1 liter = 10 deciliters = 33.81 fl. ounces
 1 dekaliter = 10 liters = 2.64 gallons
 1 hectoliter = 10 dekaliters = 26.42 gallons
 1 kiloliter = 10 hectoliters = 264.18 gallons

Square Measure

1 sq. centimeter = 100 sq. millimeters = .155 sq. inch
 1 sq. decimeter = 100 sq. centimeters = 15.5 sq. inches
 1 sq. meter (centare) = 100 sq. decimeters = 10.76 sq. feet
 1 sq. dekameter (are) = 100 sq. meters = 1,076.4 sq. feet
 1 sq. hectometer (hectare) = 100 sq. dekameters = 2.47 acres
 1 sq. kilometer = 100 sq. hectometers = .386 sq. mile

Cubic Measure

1 cu. centimeter = 1000 cu. millimeters = .06 cu. inch
 1 cu. decimeter = 1000 cu. centimeters = 61.02 cu. inches
 1 cu. meter = 1000 cu. decimeters = 35.31 feet

Approximate Conversion Factors

| <i>To change</i> | <i>To</i> | <i>Multiply by</i> | <i>To change</i> | <i>To</i> | <i>Multiply by</i> |
|------------------|--------------------|--------------------|--------------------|---------------|--------------------|
| inches | centimeters | 2.540 | ounce-inches | newton-meters | .007062 |
| feet | meters | .305 | centimeters | inches | .394 |
| yards | meters | .914 | meters | feet | 3.280 |
| miles | kilometers | 1.609 | meters | yards | 1.094 |
| square inches | square centimeters | 6.451 | kilometers | miles | .621 |
| square feet | square meters | .093 | square centimeters | square inches | .155 |
| square yards | square meters | .836 | square meters | square feet | 10.764 |
| square miles | square kilometers | 2.590 | square meters | square yards | 1.196 |
| acres | square hectometers | .405 | square kilometers | square miles | .386 |
| cubic feet | cubic meters | .028 | square hectometers | acres | 2.471 |
| cubic yards | cubic meters | .765 | cubic meters | cubic feet | 35.315 |
| fluid ounces | milliliters | 29.573 | cubic meters | cubic yards | 1.308 |
| pints | liters | .473 | milliliters | fluid ounces | .034 |
| quarts | liters | .946 | liters | pints | 2.113 |
| gallons | liters | 3.785 | liters | quarts | 1.057 |
| ounces | grams | 28.349 | liters | gallons | .264 |
| pounds | kilograms | .454 | grams | ounces | .035 |
| short tons | metric tons | .907 | kilograms | pounds | 2.205 |
| pound-feet | newton-meters | 1.356 | metric tons | short tons | 1.102 |
| pound-inches | newton-meters | .11296 | | | |

Temperature (Exact)

| $^{\circ}\text{F}$ | Fahrenheit temperature | $\frac{5}{9}$ (after subtracting 32) | Celsius temperature | $^{\circ}\text{C}$ |
|--------------------|------------------------|--------------------------------------|---------------------|--------------------|
|--------------------|------------------------|--------------------------------------|---------------------|--------------------|

This fine document...

Was brought to you by me:



[Liberated Manuals -- free army and government manuals](#)

Why do I do it? I am tired of sleazy CD-ROM sellers, who take publicly available information, slap “watermarks” and other junk on it, and sell it. Those masters of search engine manipulation make sure that their sites that sell free information, come up first in search engines. They did not create it... They did not even scan it... Why should they get your money? Why are not letting you give those free manuals to your friends?

I am setting this document FREE. This document was made by the US Government and is NOT protected by Copyright. Feel free to share, republish, sell and so on.

I am not asking you for donations, fees or handouts. If you can, please provide a link to liberatedmanuals.com, so that free manuals come up first in search engines:

<A HREF=<http://www.liberatedmanuals.com/>>Free Military and Government Manuals

- Sincerely
Igor Chudov
<http://igor.chudov.com/>
- [Chicago Machinery Movers](#)